

Series 2700A, 2700E and 2720 Control Valves

Flexible Designs:

Configurations, trims and actuators to suit your application



Series 2700A



Series 2720

The Series 2700 family of control valves offers the flexibility to select the most effective design and features for a specific application. The Series 2700 family includes three valve/actuator configurations: 2700A Standard, 2700E Extended Bonnet and 2720 Close-Coupled.

Each configuration includes a single-ported valve body with either balanced, unbalanced, full port or restricted port trims to suit a variety of flow requirements. Both plug-control and cage-control trims are available in metal-to-metal or metal-to-composition seating material for Class VI shut-off. All trims are interchangeable within the valve body.

Features

2700A Control Valve

- Balanced trims
- Plug-control trims (modified percentage, quick opening)
- Cage-control trims (linear, equal percentage, quick opening)
- 17-4PH SST standard trim
- Available with direct- or reverse-acting, yoke-mounted pneumatic diaphragm actuators
- Trim options include erosion-resistant, soft-seat ring, noise abatement and cavitation control
- Cage-control trim features dwell protected seat area
- TFE V-ring packing (non-adjustable, spring-loaded)
- Bolted closure bonnet

Series 2700E Extended Bonnet Control Valve

- Includes all 2700A features
- High and low temperature services
- Special trim and seal materials

Direct- or Reverse-Acting Actuators (2700A, 2700E)

- Available in a wide range of sizes
- Broad selection of accessories, including side- or top-mounted manual handwheel overrides, travel stops and spring ranges for all applications

- Molded diaphragm design gives precise positioning of the valve plug throughout valve travel
- Computer-designed, ductile iron yoke adds stability and strength to resist fatigue from vibration and high-frequency service or over-pressurization of the diaphragm housing
- Steel diaphragm housing helps prevent excessive deflection in over-pressure conditions
- Standard 3 to 15 psig and 6 to 30 psig spring ranges, split ranges and other spans are available

Series 2720 Control Valve with Close-Coupled Actuator

- Includes all 2700A valve features
- Space saving, economical design
- Reverse- or direct-acting, close-coupled (yokeless) actuator
- Non-adjustable, spring-loaded packing
- Interchangeable trim variations
- Visual travel indicator on the actuator housing
- Body sizes from 1 inch (25 mm) through 4 inch (100 mm)

NORRIS
PRODUCTION SOLUTIONS
A DOVER COMPANY

NORRIS
NORRIS SEAL™
A DOVER COMPANY



Contents

- 2 Configurations
- 3 Valve Specifications
- 5 Valve Trim
- 9 Actuators
- 11 How to Order
- 12 Model Code

**Engineered
Performance**

Series 2700A

Applications: general control service for a wide range of pressures, temperatures and fluids.

Operating temperatures from -50°F (-46°C) to 600°F (316°C). See **Valve Material Temperature Limits**, page 3.

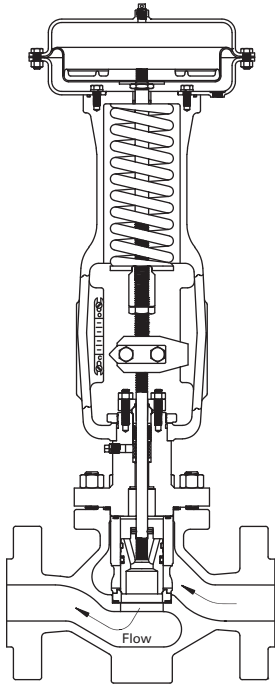

SERIES 2700A VALVE/YOKE-MOUNTED ACTUATOR ASSEMBLY

*As shown:
Cage-control trim,
TFE V-ring spring-
loaded packing,
reverse-acting
(fail-closed)
actuator*

Series 2700E

Applications: used for low-temperature service down to -150°F (-101°C) or high-temperature service up to $1,050^{\circ}\text{F}$ (566°C). See **Valve Material Temperature Limits**, page 3.

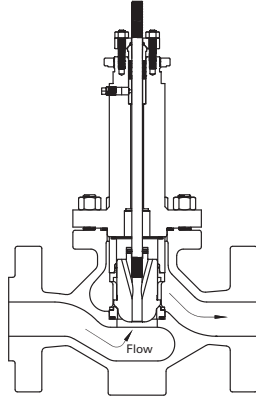

SERIES 2700E EXTENDED BONNET BODY ASSEMBLY FOR YOKE-MOUNTED ACTUATOR

*As shown:
Plug-control trim,
graphite packing*

Series 2720

Applications: provides features of the Series 2700A valve, but with a close-coupled, space-saving, economical design. Standard operating temperature up to 200°F (93°C).

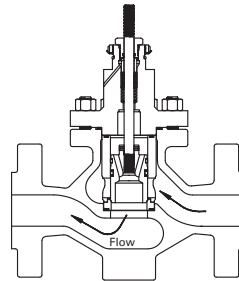

SERIES 2720 BODY ASSEMBLY FOR CLOSE-COUPLED ACTUATOR

*As shown:
Cage-control trim,
spring-loaded TFE
V-ring packing*

Design Specifications

Norriseal valves are designed in accordance with ANSI B16.34, ANSI B16.5 and ISA S75.03, S75.16.

NACE Conformance

Norriseal manufacturing procedures and material selection meet the requirements of NACE Standard Recommended Practice MR0175-02 for metallic materials used in sour service applications. Refer to **Materials of Construction** on page 3 for body/bonnet and trim materials used specifically for sour gas service to meet NACE requirements.

Quality Assurance

Norriseal is an ISO 9001-certified manufacturer. Norriseal's Quality Assurance department maintains strict control of material certificates and traceability of parts used in Norriseal control valves. The quality assurance program monitors all phases of manufacturing, finished parts and assembly to ensure conformance to all requirements.

Options

- Reduced port trims
- DB I and DB II noise abatement trims
- CAV II cavitation control valve trim
- Composition seating materials for Class VI shut-off
- Alloy 6 facing for plug and seat
- Tungsten-carbide trim
- Graphite high-temperature packing
- Adjustable packing
- Double packing
- Fugitive emissions packings
- Lubricator and isolating valve
- Drain plug in valve body
- Additional corrosion- and erosion-resistant materials

Accessories

- Manual override handwheels (side- or top-mounted)
- Manual actuator
- Electric actuator
- Travel stops
- Pressure controllers
- Pressure reducing air filter regulator
- Pressure transmitter
- Electric position transmitter
- I/P transducers
- Electric limit switches
- Solenoid valves
- All stainless steel accessory mounting hardware

VALVE MATERIAL TEMPERATURE LIMITS

Body/Bonnet			Packing		
Body/Bonnet Material	Limits		Packing Material	Limits	
	F	C		F	C
ASTM A216 Gr WCC	-20° to 800°	-29° to 427°	TFE V-Ring	-120° to 400°	-84° to 204°
ASTM A352 Gr LCC	-50° to 650°	-46° to 343°	Graphite	-300° to 1050°	-184° to 566°
ASTM A217 Gr WC6	-20° to 1050°	-29° to 566°	Kalrez®/TFE	0° to 500°	-18° to 260°
ASTM A351 Gr CF8M	-100 ⁽¹⁾ to 1000°	-73 ⁽¹⁾ to 538°			

Other packing materials available on application.

⁽¹⁾ -300°F (-184°C) with special impact testing.
Allowable pressures per ANSI B16.34.

Plug Material	Cage Material	Trim Seat Material	Limits	
			F	C
			316 SST ⁽²⁾	316 SST
316 SST/Alloy 6	316 SST ⁽³⁾⁽⁴⁾	316 SST/Alloy 6	-300° to 1050°	-184° to 566°
17-4PH SST	17-4PH SST ⁽⁴⁾	17-4PH SST	-50° to 800°	-46° to 427°
17-4PH SST/Carbide	17-4PH SST ⁽⁴⁾	316 SST/Carbide	-50° to 600°	-46° to 316°
17-4PH SST/Ceramic	17-4PH SST ⁽⁴⁾	Ceramic	-50° to 800°	-46° to 427°
Duplex SST	Duplex SST ⁽⁴⁾	Duplex SST	-20° to 750°	-29° to 399°

⁽²⁾ Shutoff pressure drop of 316 SST seat is 750 psi (51 Bar) maximum.
⁽³⁾ In a CF8M body, use full range. In a WCC or WC6 body use -20° to 600°F (-29° to 316°C).
⁽⁴⁾ Chrome plate for service above 400°F (204°C).

BODY/BONNET MATERIALS OF CONSTRUCTION

Valve Component		
Body and Bonnet	ASTM A216 Gr. WCC ASTM A351 Gr. CF8M ASTM A352 Gr. LCC	ASTM A217 Gr. WC6 Duplex Stainless Steel
Closure Studs	ASTM A193 Gr B7 ASTM A193 Gr B7M ASTM A193 Gr B8M	ASTM A320 Gr L7 ASTM A193 Gr B16
Closure Nuts	ASTM A194 Gr 2H ASTM A194 Gr 2HM ASTM A194 Gr 8M	ASTM A194 Gr 7 ASTM A194 Gr 16
Stem	303 SST Monel	17-4 PH SST 316 SST
Packing	TFE Graphite	Kalrez®/TFE Elastomeric/TFE (various)
Packing Spring	Inconel® X-750 316 SST	MP-35-N
Bonnet Gasket	316L SST/Graphite	Inconel/Graphite
Valve Stem	17-4PH SST	316 SST
Compressor Bar	316 SST	
Packing Retainer	316 SST	
Packing Studs	ASTM A193 Gr B7	
Packing Nuts	ASTM A194 Gr 2H	
Lantern Ring	316 SST	
Packing Washer	304 SST	
Bonnet Lock Nut	ASTM A536 Ductile Iron	

BODY FACE TO FACE "F" DIMENSIONS

Body End Connection Type		Body Size, Inches (mm)						
		1.0 (25)	1.5 (40)	2.0 (50)	3.0 (80)	4.0 (100)	6.0 (150)	8.0 (200)
NPT Female		■	■	11.25 (286)	N/A	N/A	N/A	N/A
Buttweld		■	■	■	■	■	■	■
Socketweld		■	■	■	N/A	N/A	N/A	N/A
ANSI Flanged Raised Face	150	7.25 (184)	8.75 (222)	10.00 (254)	11.75 (299)	13.88 (353)	17.75 (451)	21.38 (543)
	300	7.75 (197)	9.25 (235)	10.50 (267)	12.50 (318)	14.50 (368)	18.62 (473)	22.38 (568)
	600	8.25 (210)	9.88 (251)	11.25 (286)	13.25 (337)	15.50 (394)	20.00 (508)	24.00 (610)
	900	10.75 (273)	12.25 (311)	14.75 (375)	15.50 (394)	17.00 (432)	24.00 (610)	29.00 (737)
	1500	10.75 (273)	12.25 (311)	14.75 (375)	18.12 (460)	20.88 (530)	27.75 (705)	32.75 (832)
	2500	12.12 (308)	14.12 (359)	16.88 (429)	22.75 (578)	26.50 (673)	34.00 (864)	40.25 (1022)
ANSI Flanged Ring-Type Joint	150	7.75 (197)	9.25 (235)	10.50 (267)	12.25 (311)	14.38 (365)	18.25 (464)	21.88 (556)
	300	8.25 (210)	9.75 (248)	11.12 (282)	13.12 (333)	15.12 (384)	19.25 (489)	23.00 (584)
	600	8.25 (210)	9.88 (251)	11.38 (289)	13.38 (340)	15.62 (397)	20.12 (511)	24.12 (613)
	900	10.75 (273)	12.25 (311)	14.88 (378)	15.62 (397)	17.12 (435)	24.12 (613)	29.12 (740)
	1500	10.75 (273)	12.25 (311)	14.88 (378)	18.25 (464)	21.00 (533)	28.00 (711)	33.12 (841)
	2500	12.12 (308)	14.25 (362)	17.00 (432)	23.00 (584)	26.88 (683)	34.50 (876)	40.88 (1038)

■ Dimension depends on body rating; consult factory.

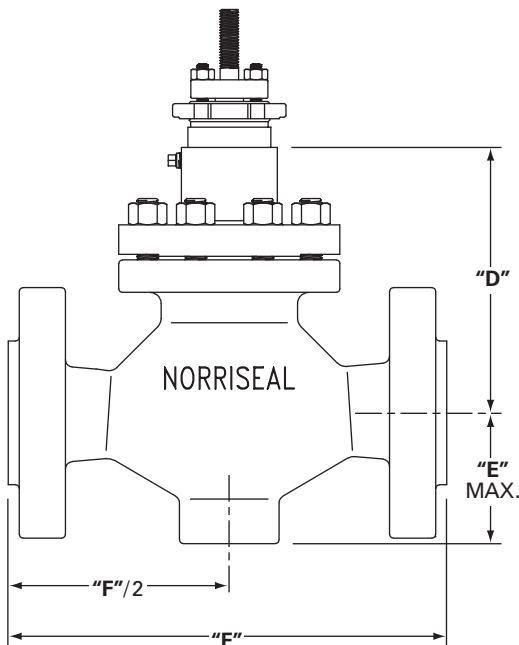

BODY HEIGHT

Body Size, Inches (mm)	"D," Inches (mm)		"E" Max., Inches (mm)
	2700A/2720	2700E	
1.0 (25)	6.56 (167)	10.56 (268)	3.50 (89)
1.5 (40)	7.29 (185)	11.29 (287)	4.06 (103)
2.0 (50)	9.00 (229)	13.75 (349)	4.56 (116)
3.0 (80)	9.25 (235)	14.00 (356)	6.38 (162)
4.0 (100)	10.19 (259)	14.94 (379)	7.62 (194)
6.0 (150)	12.44 (316)	17.44 (443)	7.62 (194)
8.0 (200)	16.00 (406)	21.00 (533)	10.50 (267)

Dimensions are approximate for 1" to 4" 150 to 1500 class and 6" to 8" 150 to 600 class. Consult factory for other body size/pressure class combinations.

AVAILABLE BODY END CONNECTIONS

Body Size, Inches (mm)	NPT	Butt Weld	Socket Weld	ANSI Flanged RF and RTJ					
				150	300	600	900	1500	2500
1.0 (25)	■	■	■	■	■	■	■	■	■
1.5 (40)	■	■	■	■	■	■	■	■	■
2.0 (50)	■	■	■	■	■	■	■	■	■
3.0 (80)		■		■	■	■	■	■	■
4.0 (100)		■		■	■	■	■	■	■
6.0 (150)		■		■	■	■	■	■	■
8.0 (200)		■		■	■	■	■	■	■

BODY AND TRIM SIZE COMBINATIONS

Body Size, Inches (mm)	Nominal Trim Size, Inches (mm)							
	Unbalanced 0.19–1.00 (4.8–25)	Balanced						8.0 (200)
		1.0 (25)	1.5 (40)	2.0 (50)	3.0 (80)	4.0 (100)	6.0 (150)	
1.0 (25)	■	■						
1.5 (40)	■	■	■					
2.0 (50)	■	■	■	■				
3.0 (80)	■	■	■	■	■			
4.0 (100)	■	■	■	■	■	■		
6.0 (150)				■	■	■	■	
8.0 (200)						■	■	■

Cage-Control Trim

Cage-control trim is designed primarily for process applications. These pressure-balanced, precision-guided trims feature proprietary Norriseal seating surface with Protection Geometry. This design redirects erosive forces of the fluid stream away from critical surfaces of the plug and seat to extend service life.

Characteristics:

- Linear
- Equal percentage
- Quick opening
- DB I and DB II noise abatement
- CAV II cavitation control

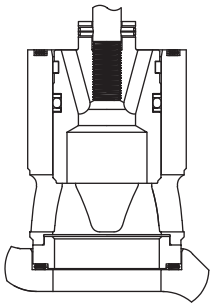

*Linear
Flow Down*

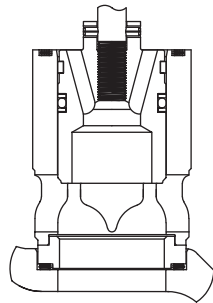

*Equal Percentage
Flow Down*

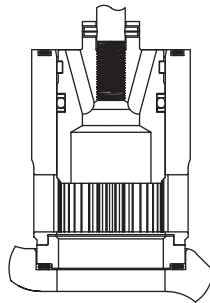

*DB I
Flow Up*

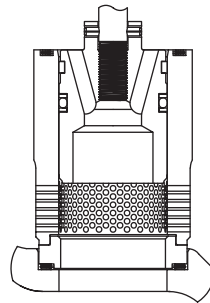

*CAV II – Flow Down
DB II – Flow Up*

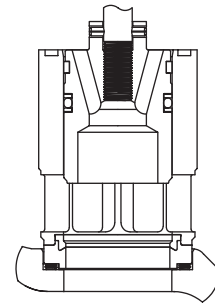

*Quick Opening
with Soft Insert
Flow Down*

Plug-Control Trim

Plug-control trim is a rugged, field-proven trim best suited for slurries and other “dirty” fluids. Norriseal offers a wide selection of pressure-balanced, top-guided, contoured plug-control trims.

Characteristics:

- Modified percentage (Balanced and Unbalanced)
- Equal percentage
- Quick opening (Balanced and Unbalanced)

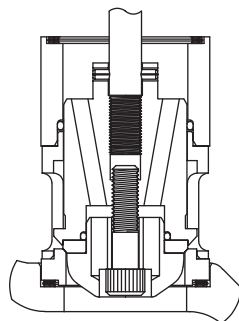

*Modified Percentage
Hard or Soft Plug
Insert – Flow Up*

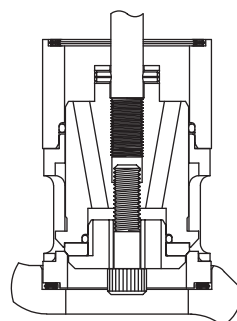

*Quick Opening
Hard or Soft Plug
Insert – Flow Up*

TRIM MATERIALS OF CONSTRUCTION			
Trim Component	Material		
	Standard	NACE	Optional
Balanced Cage-Control Trim			
Plug	17-4PH SST H1150M	316 SST	316 SST/Alloy 6 Monel® or Duplex SST
Cage	17-4PH SST H1150M/Chrome	316 SST	316 SST/Chrome Monel® or Duplex SST
Plug Seal	Fluoroelastomer	Fluoroelastomer	Nitrile Ryton® Fluoroloy-K® Kalrez® Carbon-Graphite
Seat Ring	17-4PH SST H1150M	316 SST	316 SST/Alloy 6 Monel® or Duplex SST
Soft Seat Insert	Carbon-Graphite-filled TFE	Carbon-Graphite-filled TFE	Kynar® Fluoroloy-K®
Bearing Ring	Carbon-Graphite-filled TFE	Carbon-Graphite-filled TFE	Ryton® Carbon-Graphite
Trim Gaskets	316L SST/Graphite	Inconel®/Graphite	As Required to Suit Specific Application
Plug/Stem Pin	420 SST	316 SST	
Reduced Trim Adapter	316 SST	316 SST	
Valve Stem	17-4PH SST H1150M	316 SST	316 SST/Chrome Nitronic 50®
Balanced Plug-Control Trim			
Plug	17-4PH SST H1150M	316 SST	316 SST/Alloy 6 316 SST/Tungsten-Carbide 316 SST/Ceramic
Soft Plug Insert	Glass-Filled TFE	Glass-Filled TFE	As Required to Suit Specific Application
Guide	316 SST	316 SST	
Cage	17-4PH SST H1150M	316 SST	
Plug Seal	TFE (1"– 4" sizes) TFE/Elgiloy® (6" and 8" sizes)	TFE (1"– 4" sizes) TFE/Elgiloy® (6" and 8" sizes)	Fluoroloy-K®/Elgiloy® Carbon-Graphite
Seat Ring	17-4PH SST H1150M	316 SST	316 SST/Alloy 6 316 SST/Tungsten-Carbide 316 SST/Ceramic
Trim Gaskets	316L SST/Graphite	Inconel®/Graphite	As Required to Suit Specific Application
Plug/Stem Pin	420 SST	316 SST	
Valve Stem	17-4PH SST H1150M	316 SST	316 SST/Chrome Nitronic 50®
Unbalanced Plug-Control Reduced C_v Trim			
Plug	17-4PH SST H1150M	316 SST	316 SST/Alloy 6 316 SST/Tungsten-Carbide 316 SST/Ceramic
Seat/Cage	17-4PH SST H1150M	316 SST	316 SST/Alloy 6 316 SST/Tungsten-Carbide 316 SST/Ceramic
Seat/Cage Seal	Fiberglass/Graphite (1" & 1.5" Valves) Fluoroelastomer (2"–4" Valves)	Fiberglass/Graphite (1" & 1.5" Valves) Fluoroelastomer (2"–4" Valves)	Nitrile EPDM Aflas® Perfluoroelastomer
Plug/Stem Pin	420 SST	316 SST	As Required to Suit Specific Application
Reduced Trim Adapter(s)	316 SST	316 SST	
Valve Stem	17-4PH SST H1150M	316 SST	316 SST/Chrome Nitronic 50®

TYPICAL TRIM CHARACTERISTIC CURVES

For actual data, reference C_v charts on page 8.

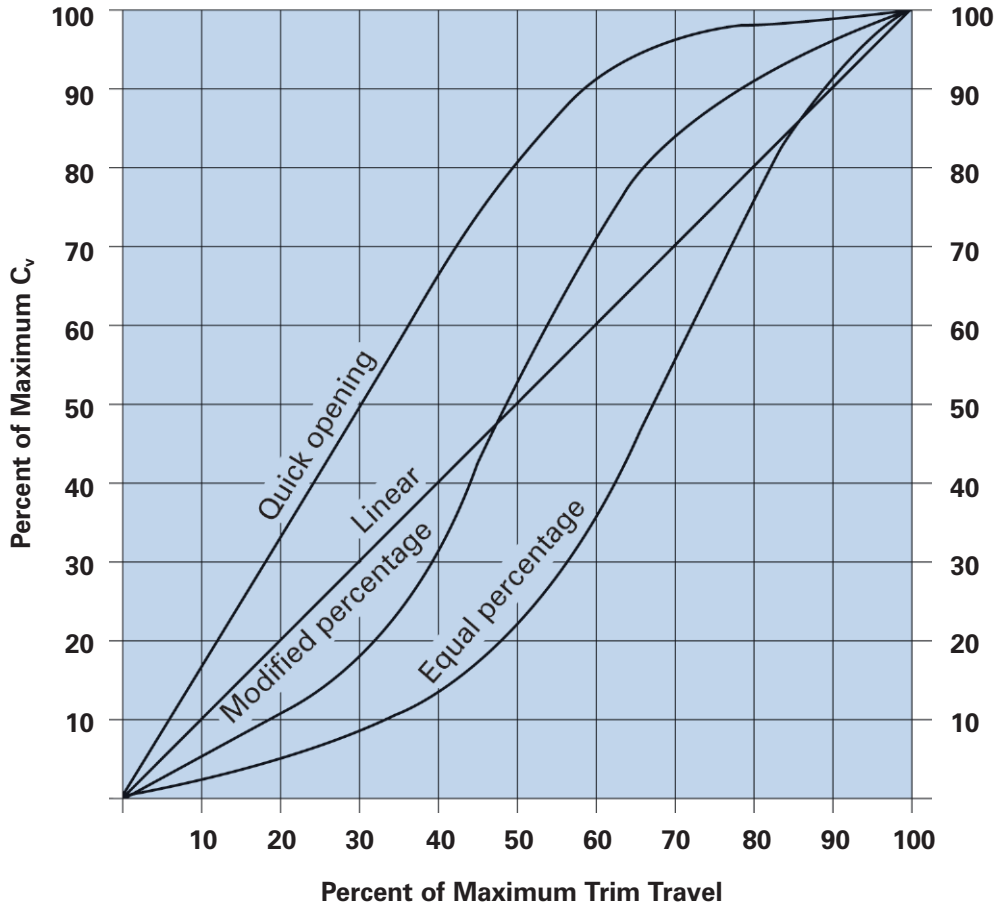

- Linear — flow capacity is directly proportional to valve plug travel
- Equal Percentage — changes in flow rate will be small in comparison to plug travel when the plug is near the seat and large when the plug exceeds 50% travel
- Modified Percentage — provides low-end throttling capability combined with linear, mid-range gain to achieve both precise control and maximum top-end flow capacity
- Quick Opening — generally applicable to On/Off control, it provides maximum increase in flow rate at low valve plug travel
- CAV II — controls cavitation damage and reduces flow noise; has a linear characteristic
- DB I and DB II — attenuates compressible flow noise from gas turbulence; has a linear characteristic

NOTES

Seat Leakage (ANSI/FCI 70-2). Norriseal trims provide Class II, IV or V tightness with metal seats and class VI tightness with composition seats.

Flow Coefficients. The following page displays flow coefficients (C_v) for commonly used trim sizes and characteristics. Refer to Norriseal Valve Sizing Program for balanced reduced-port, noise abatement and cavitation control C_v data.

Caution: Pressure Drop Ratings. The rated pressure drop may be less than the body's rated working pressure. The rated shutoff pressure drop is dependent on the actuator's size, spring range, air pressure and seat leakage class. For a chart containing actual pressure drops, please refer to the Norriseal Valve Sizing Manual or contact your Norriseal representative.

FLOW COEFFICIENTS (C_v) FOR BALANCED CAGE-CONTROL TRIMS (LINEAR & EQUAL PERCENTAGE)

Body Size Inches (mm)	Trim Size Inches (mm)	Charac- teristic	Valve Opening — Percent Total Travel									
			10	20	30	40	50	60	70	80	90	100
1.0 (25)	1.0 (25)	Linear	.355	1.01	2.48	5.46	8.43	11.3	14.3	16.9	18.6	19.6
		E.P.	.308	.565	1.21	2.63	4.83	8.16	12.4	15.5	17.8	18.9
1.5 (40)	1.5 (40)	Linear	.906	3.26	7.35	13.1	20.2	27.7	34.5	39.8	43.5	45.5
		E.P.	.400	.813	2.36	4.86	8.49	15.1	22.7	30.3	35.5	39.2
2.0 (50)	2.0 (50)	Linear	1.51	4.87	11.0	20.3	30.9	41.5	50.2	57.0	61.4	64.8
		E.P.	.643	2.20	4.82	9.29	15.6	25.9	39.5	53.0	58.5	62.0
3.0 (80)	3.0 (80)	Linear	3.23	8.30	19.6	37.6	55.8	73.7	88.9	101	110	117
		E.P.	.906	3.31	7.72	15.4	27.7	46.8	70.1	93.7	108	116
4.0 (100)	4.0 (100)	Linear	8.57	21.2	42.7	68.5	94.0	120	145	168	184	195
		E.P.	2.83	9.09	19.5	33.9	52.0	79.8	119	159	185	195
6.0 (150)	6.0 (150)	Linear	19.6	55.8	104	152	200	248	296	339	369	391
		E.P.	6.84	19.6	40.1	69.6	107	163	244	325	360	378
8.0 (200)	8.0 (200)	Linear	55.3	125	224	324	422	521	618	705	752	790
		E.P.	18.1	44.1	86.9	143	221	346	494	642	728	756

FLOW COEFFICIENTS (C_v) FOR BALANCED PLUG-CONTROL TRIMS (QUICK OPENING, MODIFIED PERCENTAGE)

Body Size Inches (mm)	Trim Size Inches (mm)	Charac- teristic	Valve Opening — Percent Total Travel									
			10	20	30	40	50	60	70	80	90	100
1.0 (25)	1.0 (25)	Q.O.	8.83	14.0	17.4	19.2	20.2	20.9	21.2	21.5	21.7	21.9
		M.P.	1.17	2.29	3.82	6.65	10.9	15.2	17.7	19.3	20.2	20.5
1.5 (40)	1.5 (40)	Q.O.	13.2	26.4	37.2	44.3	49.1	52.4	54.2	54.8	55.3	55.9
		M.P.	3.13	6.06	9.68	17.7	28.8	40.0	47.2	51.6	54.0	54.8
2.0 (50)	2.0 (50)	Q.O.	19.6	38.7	55.2	62.7	65.6	67.5	68.8	70.0	71.3	72.8
		M.P.	5.01	11.0	20.3	33.8	48.9	61.4	67.2	69.5	70.8	71.6
3.0 (80)	3.0 (80)	Q.O.	27.5	54.5	81.8	102	115	122	126	127	129	130
		M.P.	6.15	14.9	27.7	52.5	80.3	104	118	124	128	129
4.0 (100)	4.0 (100)	Q.O.	30.4	64.5	103	142	175	195	204	210	212	213
		M.P.	8.42	21.6	38.3	71.5	114	148	177	196	207	211
6.0 (150)	6.0 (150)	Q.O.	55.2	117	189	271	333	374	406	427	440	444
		M.P.	19.8	40.1	76.7	128	192	252	312	352	378	400
8.0 (200)	8.0 (200)	Q.O.	90.3	217	354	505	631	725	797	841	872	885
		M.P.	36.3	75.2	138	242	375	522	641	723	780	805

FLOW COEFFICIENTS (C_v) FOR UNBALANCED PLUG-CONTROL TRIMS (MODIFIED PERCENTAGE AND EQUAL PERCENTAGE)

Body Size Inches (mm)	Trim Size Inches (mm)	Charac- teristic	Valve Opening — Percent Total Travel									
			10	20	30	40	50	60	70	80	90	100
1.0 (25) 1.5 (40) 2.0 (50)	0.19 (5)	E.P.	.002	.007	.016	.027	.040	.057	.101	.191	.320	.561
		M.P.	.284	.506	.657	.767	.875	.989	1.10	1.20	1.32	1.43
	0.25 (6)	E.P.	.043	.061	.095	.146	.229	.338	.477	.717	1.19	1.42
		M.P.	.311	.621	.942	1.28	1.64	2.07	2.51	2.93	3.35	3.70
	0.38 (10)	E.P.	.092	.140	.220	.341	.495	.717	1.14	2.06	2.91	3.13
		M.P.	.557	1.11	1.68	2.26	2.92	3.62	4.30	4.98	5.43	5.60
0.50 (13)	E.P.	.098	.162	.265	.442	.740	1.52	2.58	3.64	4.68	5.20	
	M.P.	.752	1.57	2.43	3.42	4.58	6.08	7.93	9.71	10.6	11.0	
1.0 (25)	0.75 (19)	E.P.	.185	.334	.481	.835	2.17	3.98	5.79	7.61	8.82	9.25
		M.P.	.983	2.01	3.40	6.12	8.90	11.7	13.5	14.4	15.1	15.4
1.5 (40)	0.75 (19)	M.P.	.882	1.76	2.76	3.82	5.05	6.57	8.49	10.8	12.2	12.9
		E.P.	.185	.334	.481	.835	2.17	3.98	6.20	8.46	10.1	10.9
2.0 (50)	1.00 (25)	M.P.	.964	1.92	3.08	4.67	6.96	10.0	13.0	14.7	15.5	16.3
		E.P.	.882	1.76	2.76	3.82	5.53	7.78	10.2	12.6	15.0	16.2
2.0 (50)	0.75 (19)	M.P.	.882	1.76	2.76	3.82	5.53	7.78	10.2	12.6	15.0	16.2
		E.P.	.185	.334	.481	.835	2.17	3.98	6.20	8.46	10.1	10.9
2.0 (50)	1.00 (25)	M.P.	1.01	2.02	3.14	5.07	9.68	11.9	14.9	17.2	19.3	20.9
		E.P.	.185	.334	.481	.835	2.17	3.98	6.20	8.46	10.1	10.9

Series 2700A and 2700E Yoke-Mounted

Norriseal direct- or reverse-acting, pneumatic diaphragm, spring-return actuators are integral to Series 2700A and 2700E assemblies. Using a pneumatic input signal from a positioner, pressure controller, liquid level controller, temperature

controller or transducer, these actuators move the valve plug to the required position for both throttling or On/Off service. The yoke provides a means for mounting accessories requiring valve motion take-off.

Direct-Acting

This is a fail-open, push-down-to-close style actuator. Applying pneumatic pressure to the upper diaphragm housing forces the valve plug downward to engage the valve seat. Reducing the pressure on the diaphragm enables the opposing spring force to raise the valve plug upward, opening the valve.

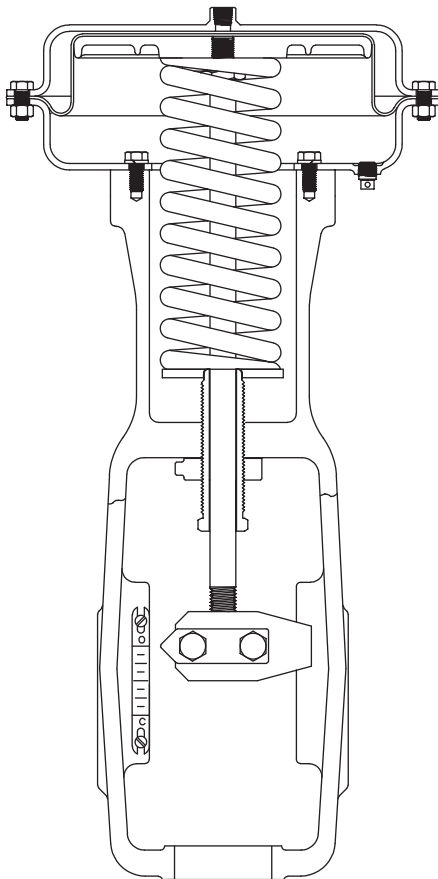

*Direct-Acting
(Fail-Open)*

Reverse-Acting

This is a fail-closed, push-up-to-open style actuator. Applying pneumatic pressure to the lower diaphragm housing raises the valve plug upward against the opposing spring force, which opens the valve. Reducing pneumatic pressure to the diaphragm causes the spring to move the valve plug downward, closing the valve.

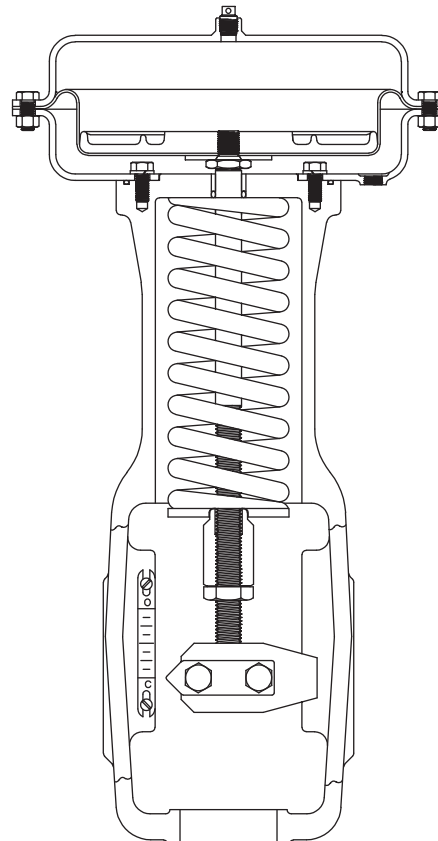

*Reverse-Acting
(Fail-Closed)*

BODY AND ACTUATOR COMBINATIONS

Body Size Inches (mm)	Actuator Size and Effective Area (sq. in.)			Maximum Stem Travel	
	No. 12 70 in. ²	No. 16 120 in. ²	No. 18 180 in. ²	Inches	mm
1.0 (25)	■	■		0.75	19
1.5 (40)	■	■	■	1.00	25
2.0 (50)	■	■	■	1.25	32
3.0 (80)	■	■	■	1.50	38
4.0 (100)	■	■	■	2.00	51
6.0 (150)			■	2.75	70
8.0 (200)			■	4.00	102

ACTUATOR MATERIALS

Actuator Component	Material
Yoke	Ductile iron
Diaphragm	Nitrile with nylon fabric*
Diaphragm housings	Carbon steel
Diaphragm plate	Carbon steel
Stem	303 SST
Stem connector	316 SST
Spring	AISI 5160
Adjusting screw	AISI 1215/Zinc Plated

*Other materials available.

DIRECT- AND REVERSE-ACTING YOKE-MOUNTED ACTUATOR DIMENSIONS

Actuator Size (Applicable Valve Sizes)	A Inches (mm)	B Inches (mm)	C, Inches (mm)		D* Inches (mm)	E* Inches (mm)	F Inches (mm)	G Inches (mm)
			Direct	Reverse				
No. 12 SU (1 & 1.5)	12.50 (318)	2.81 (71)	18.01 (457)	19.14 (486)	11.25 (286)	9.00 (229)	11.75 (298)	9.00 (229)
No. 12 MU (1-4)	12.50 (318)	2.81 (71)	25.25 (641)	24.25 (616)	13.12 (333)	12.00 (305)	15.00 (381)	12.00 (305)
No. 16 HU (1-4)	16.75 (425)	2.81 (71)	29.50 (749)	31.75 (806)	13.12 (333)	12.00 (305)	17.00 (432)	18.00 (457)
No. 18 HU (1.5-4)	20.50 (521)	2.81 (71)	30.62 (778)	33.05 (839)	16.50 (419)	18.00 (457)	17.00 (432)	18.00 (457)
No. 18 KU (6)	20.50 (521)	3.19 (81)	30.62 (778)	33.05 (839)	17.38 (441)	18.00 (457)	17.00 (432)	18.00 (457)
No. 18 LU (6 & 8)	20.50 (521)	3.56 (90)	46.22 (1174)	50.81 (1291)	18.62 (473)	18.00 (457)	17.00 (432)	18.00 (457)

*Dimensions shown for Style 17 top-mounted limit stop.

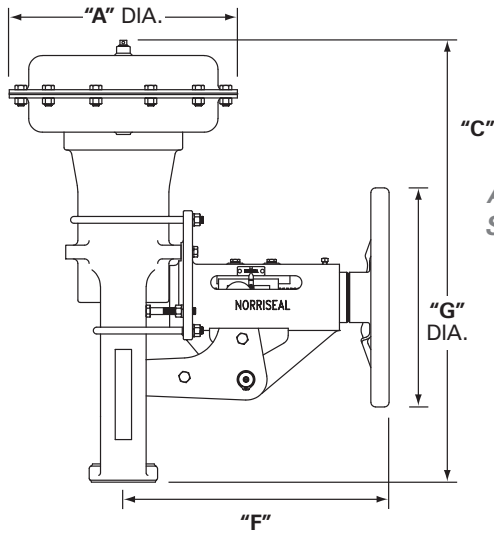

Actuator with Side-Mounted Handwheel

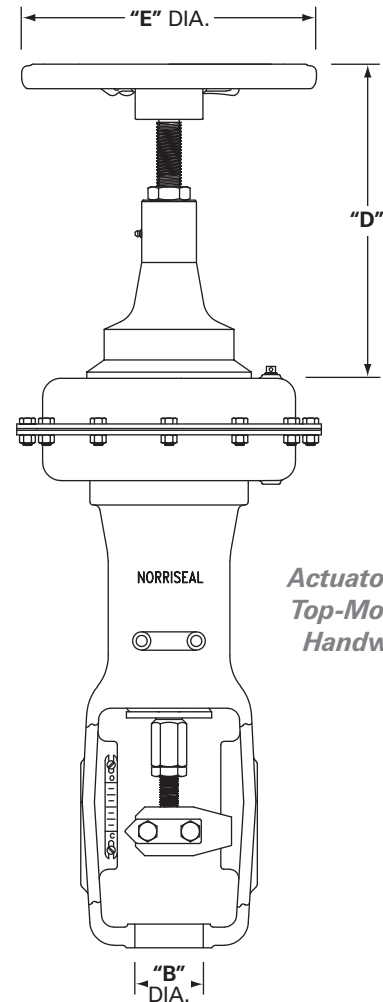

Actuator with Top-Mounted Handwheel

Handwheels

Norriseal offers a range of handwheels for manual assistance in regulating stem travel or positioning the control valve plug to override the actuator in case of pneumatic pressure failure.

Top-Mounted. Normally used as a manual or adjustable travel stop.

Side-Mounted. Limits travel by moving the actuator/valve stem in the direction opposite the actuator spring to any point within the valve travel. Automatic pneumatic operation throughout valve travel is possible with the handwheel in neutral position. A spring-loaded ball detent is furnished to stabilize the handwheel setting in vibration service.

Series 2720 Close-Coupled

A yokeless space-saving arrangement, close-coupled Series 2720 actuators mount directly to the valve bonnet with the adjustable spring positioned above the diaphragm. Operation is identical

to that of the yoke-mounted actuators and available as either direct-acting (fail-open, push-down-to-close) or reverse-acting (fail-closed, push-up-to-open).

Direct-Acting

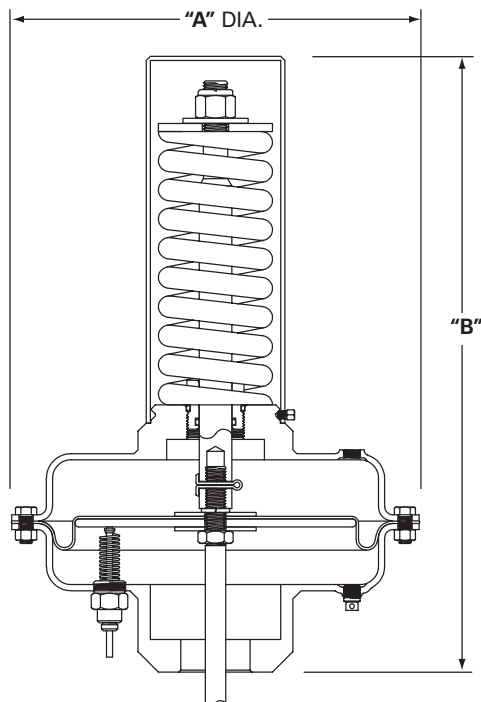

Reverse-Acting

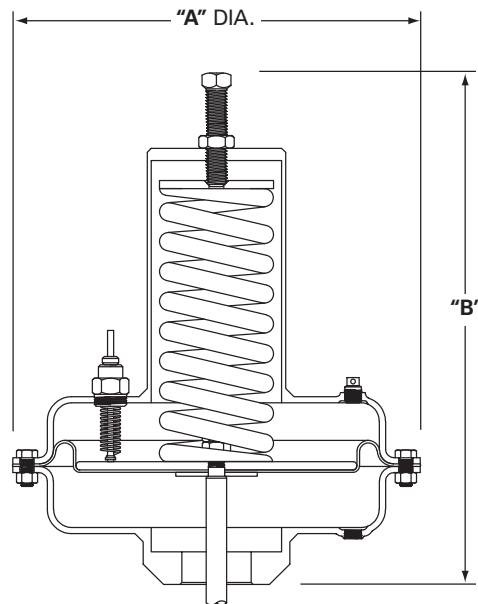

ACTUATOR DIMENSIONS CLOSE-COUPLED

Actuator Size (Applicable valve sizes)	A Inches (mm)	B, Inches (mm)	
		Direct	Reverse
No. 12 (1, 1.5, 2, 3 & 4)	12.50 (318)	20.06 (510)	16.50 (419)
No. 16 (1, 1.5, 2, 3 & 4)	16.75 (425)	22.88 (581)	24.50 (622)
No. 18 (1.5, 2, 3 & 4)	20.50 (521)	23.75 (603)	26.50 (673)

ACTUATOR MATERIALS

Actuator Component	Material
Diaphragm	Nitrile with nylon fabric
Diaphragm housings	Carbon steel
Stem	316 SST
Spring	AISI 5160

How to Order

If known, specify:

1. Body size, series/style and material (Example: 4-inch body in Series 2700A = 4-2700A)
2. Trim size and material
3. Throttling or On/Off service
4. Actuator size, action and spring range
5. Optional equipment/accessories required
6. Controlled fluid (include chemical analysis when available)
7. Specific gravity of controlled fluid
8. Fluid temperature
9. Range of flowing inlet pressure
10. Pressure drops
 - a. Range of pressure drops
 - b. Maximum at shutoff
11. Flow rates
 - a. Minimum controlled flow
 - b. Normal flow
 - c. Maximum flow
12. Maximum permissible noise level (if critical)
13. Shutoff classification required
14. Line size and schedule
15. Optional equipment

Series definition:

- 2700A** — Standard bonnet with open-yoke actuator
- 2700E** — Extended bonnet with open-yoke actuator
- 2720** — Valve with close-coupled actuator

If not known, specify:

1. Type of application
 - a. Throttling or On/Off
 - b. Back pressure (relief) or pressure reducing

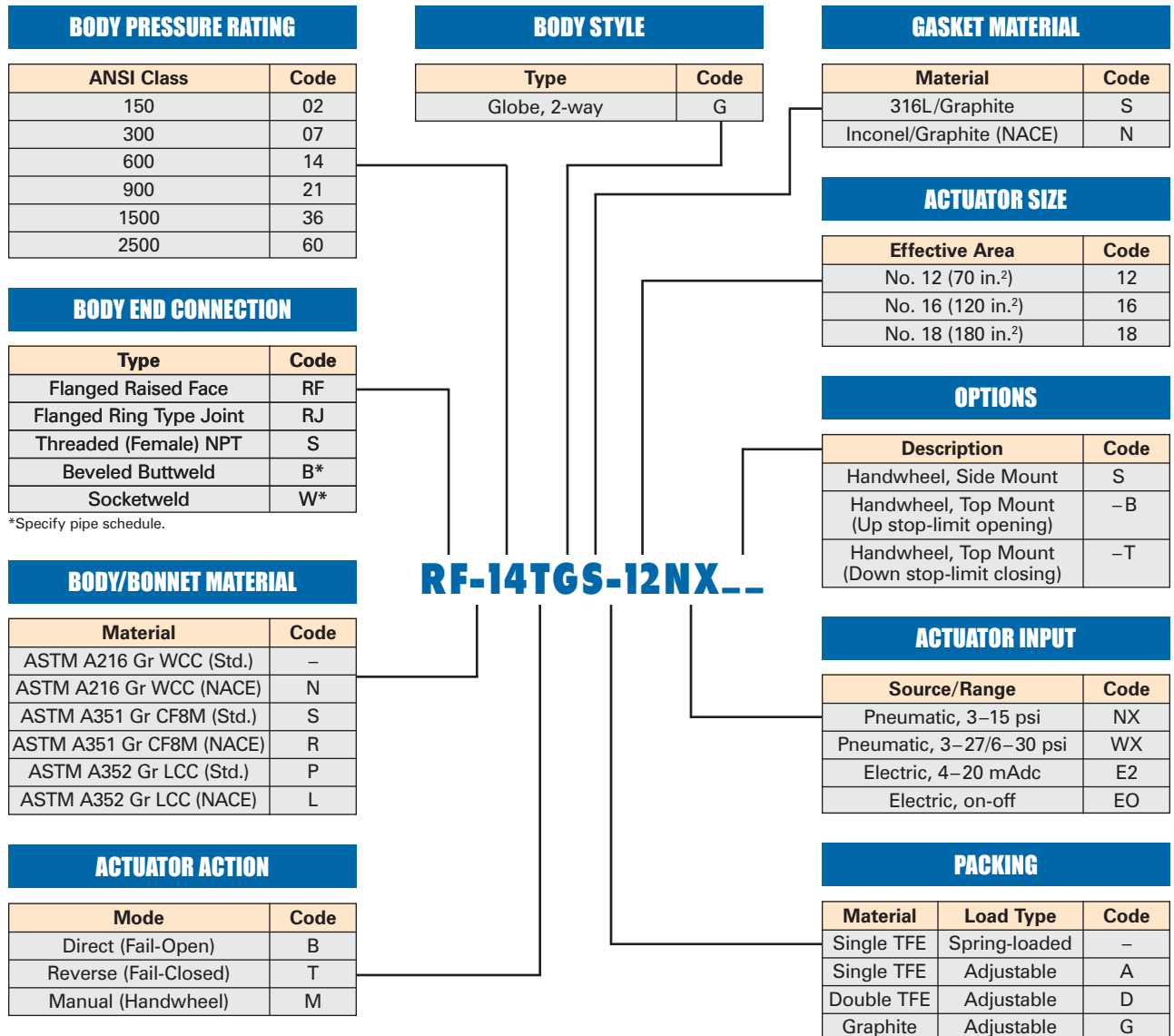

Accessories

Positioners (electro-pneumatic, pneumatic), airlock, limit switches, solenoid valve, booster relay, filter regulators, I/P transducers, pressure controllers, temperature controllers, etc.

⁽¹⁾Example is for the purpose of displaying Model Code structure and not intended to identify all available materials and configurations.

FUGITIVE EMISSION PACKING		
Material	Load Type	Code
FES-I	Non-adjustable	*
FES-II	Non-adjustable	K

*Application dependent; consult factory.



Engineered Performance

11122 West Little York • Houston, Texas 77041

Tel: 713-466-3552 • Fax: 713-896-7386

www.norriseal.com

Due to the continuous improvement program at Norriseal, specifications and/or prices are subject to change without notice or obligation.

All trademarks contained herein are the property of their respective owners.

© 2011 Norriseal, A Dover Company

2700-0104T