

SERIES 6300 HEAVY-DUTY, HIGH-PRESSURE REGULATOR

The Series 6300 heavy-duty/high-pressure regulator is a spring-loaded, self-contained, pressure-reducing regulator available in 1" and 2" NPT sizes. Ruggedly constructed to endure the most demanding environments, the Series 6300 regulator is commonly used for first-stage pressure reduction to manage natural gas pressures on process equipment. Inlet maximum pressure is 1,500 psig (103.4 bar) with outlet pressure ranging from 30 psig to 500 psig (2.1 to 34.5 bar).

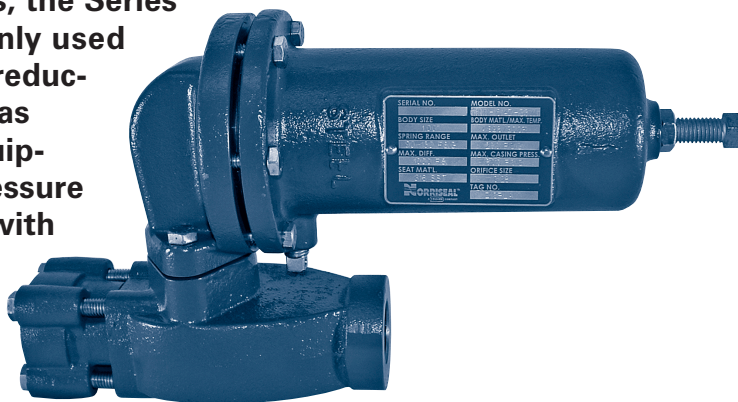

- Simple maintenance
- Multiple flow capacity options
- NACE option (MR0175 2002)
- Robust construction

Regulator Specifications:

- Body Sizes
 - 1 inch (DN 25)
 - 2 inch (DN 50)
- End Connection Style
 - FNPT screwed
- Maximum Inlet Pressure and Pressure Drop*
 - Up to 1,500 psig (103 bar), See Table 2 on page 3
- Maximum Outlet Pressure*
 - Up to 500 psig (34.5 bars), See Table 1 on page 3
- Pressure Registration
 - Internal
- Orifice Sizes (inches)
 - 1/8, 3/16, 1/4, 3/8, 1/2
- Full Open Flow Coefficients
 - 0.43 Cv to 6.75 Cv
- Flow Capacities
 - Refer to Series 6300 Operating and Maintenance Manual at www.norriseal.com
- Temperature Capabilities*
 - Nitrile (NBR), Nylon (PA) and Neoprene (CR):
-22°F to 180°F (-29°C to 82°C)
 - Fluoroelastomer (FKM), Teflon® (TFE):
0°F to 300°F (-18°C to 149°C)

Contents

- 2 Construction Materials
- 2 Installation
- 3 Specifications
- 4 Model Code

*The pressure temperature limits in the Operating and Maintenance Manual and any applicable standard or code limitation should not be exceeded.

- **Body:** Ductile iron or WCC steel
- **Spring Case and Diaphragm Adapter:** Ductile iron or WCC steel
- **Orifice:** Stainless steel
- **Valve Seat:** Nylon (PA), Teflon® (TFE), or fluoroelastomer (FKM)
- **Valve Seat Holder:** Stainless steel
- **Seat Carrier:** Stainless steel
- **Diaphragm:** Neoprene (CR) or fluoroelastomer (FKM)
- **All Gaskets:** Composition
- **Lever:** Zinc-plated steel
- **Vent:** Aluminum
- **Pitot Tube:** Stainless-steel tube
- **Regulator Spring:** Plated steel
- **Adjusting Screw:** Zinc-plated steel
- **Upper Spring Retainer:** Zinc-plated steel
- **Lower Spring Retainer:** Zinc-plated steel
- **Diaphragm Connector:** Stainless steel
- **Options:** NACE

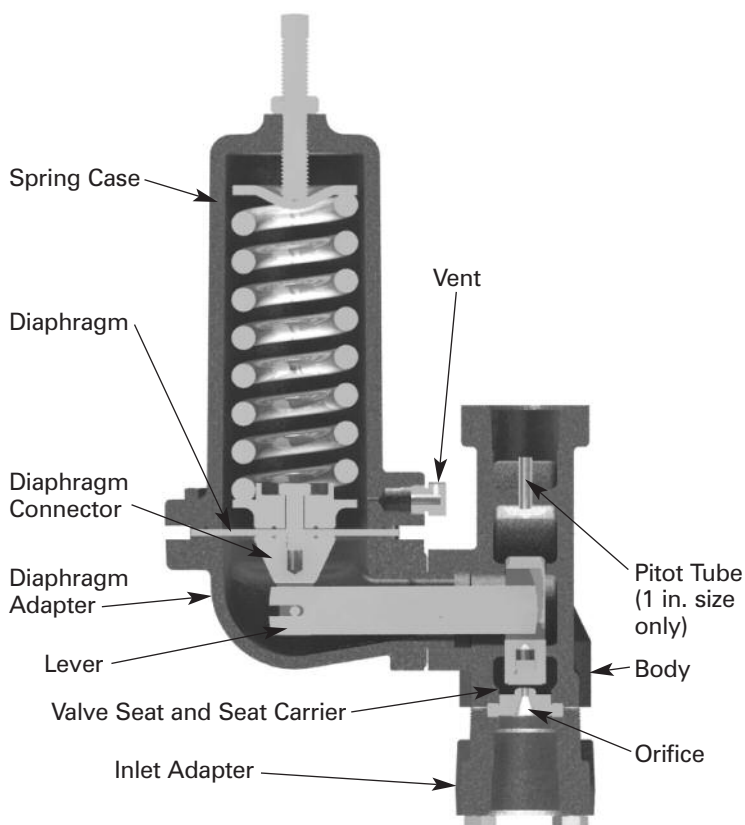

Full Section

FLOW CAPACITY DATA

For flow capacity data and spring sizing information, refer to the Series 6300 Operating and Maintenance Manual at www.norriseal.com.

INSTALLATION

The regulator may be installed in any position, noting that the spring case vent must be positioned to protect against flooding, drain water, ice formation, traffic, tampering, etc. The vent must also be protected against nest-building insects to prevent blockage and to minimize the chances of foreign material amassing in the vent side of the regulator diaphragm. Additionally, the flow of product through the regulator must be in the direction indicated by the arrow on the spring casing.

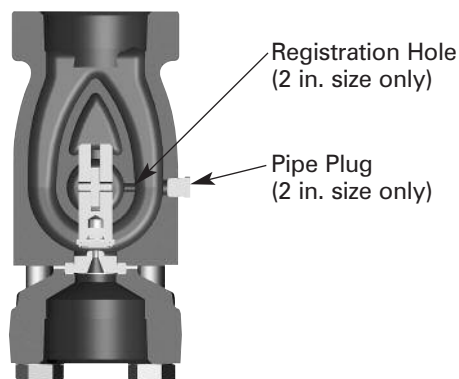

Body & Inlet Adapter Only



CAUTION – Series 6300 regulators have an outlet pressure rating that is lower than the inlet pressure rating – overpressure protection is required if the actual inlet pressure can exceed the regulator’s outlet pressure rating. To avoid overpressure, provide an appropriate protection device to ensure the limits listed in the specifications will not be exceeded.

TABLE 1: OUTLET PRESSURE RANGE

	Outlet Pressure psig (bar)	Maximum Outlet Pressure Over Pressure Setting ² psig	Maximum Emergency Outlet Pressure, psig
High Pressure	30-50 (2.1-3.4)	200	550
	45-95 (3.1-6.5)		
	90-150 (6.2-10.3)		
	150-200 (10.3-13.8)		
	200-275 (13.8-18.9)		
	275-500 (18.9-34.5)	200 ¹	

1. This applies to outlet pressure settings below 350 psig only. For pressure settings above 350 psig, outlet pressure is limited to 550 psig, the maximum emergency outlet pressure.
2. Internal parts of the regulator may be damaged if the outlet pressure exceeds the pressure setting beyond the amounts shown.

TABLE 2: MAXIMUM OUTLET & DIFFERENTIAL PRESSURE

Orifice Size Inches (mm)	Maximum Allowable Inlet Pressure, psig ¹ (bar)	Maximum Allowable Pressure Drop, PSID	
		TFE or Nylon Disk	Viton disk
1/8 (3.2) or 3/16 (4.8)	1,500 (103.4)	1,500	200
1/4 (6.4)	1,500 (103.4)	1,000	
3/8 (9.5)	1,000 (68.9)	500	
1/2 (16.7)	750 (51.7)	250	

1. The sum of the outlet pressure setting and the maximum allowable pressure drop determines the maximum allowable inlet pressure for a given installation. For example, with a 1/2 in. port diameter (maximum pressure drop of 250 psi) and a 400 psig outlet pressure setting, the maximum inlet pressure is 650 psig (250 psi plus 400 psig).

DIMENSIONS

Body Size	A Inches (mm)	B Inches (mm)	C Inches (mm)	D Inches (mm)	E Inches (mm)	F Inches (mm)	Weight lbs (kg)
1" NPT	7.41 (188)	3.72 (94)	4.69 (119)	7.17 (182)	1.26 (32)	12.67 (322)	22 (10.0)
2" NPT	7.87 (200)	3.96 (101)	4.69 (119)	7.17 (182)	1.94 (49)	12.90 (328)	29 (13.2)

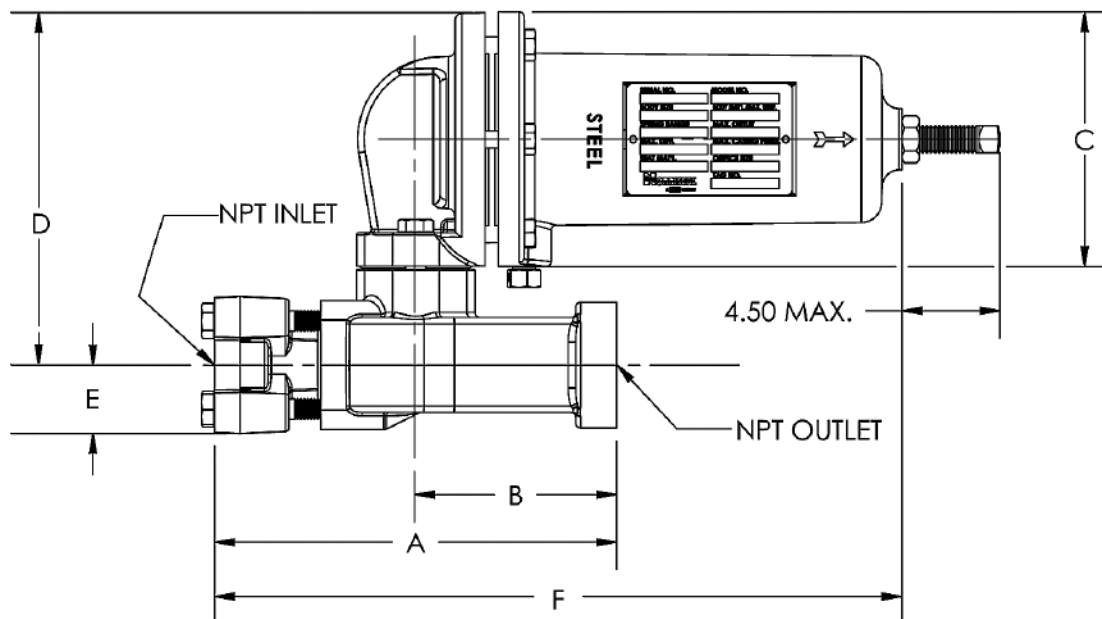



MODEL CODE

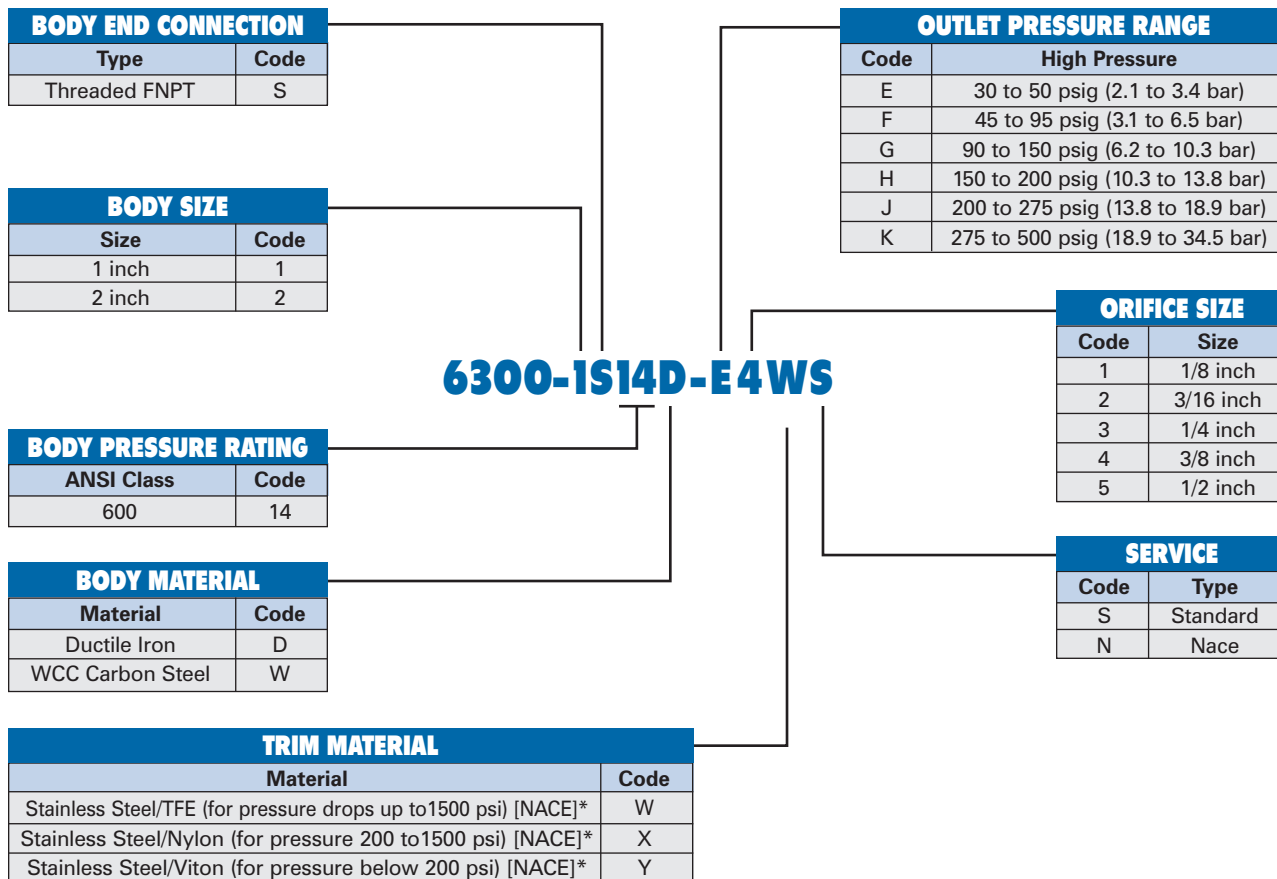

* See Table 2 on Page 3

Why you can depend on genuine Norriseal products

- In-house engineering and technical support
- In-depth applications experience
- Award-winning innovation and ongoing product development
- ISO 9001-certified manufacturing
- Over five decades of industry service
- Compliance with all industry standards and specifications
- Responsive service and prompt delivery
- Field support available worldwide

Please contact your Norriseal representative for more details and assistance in specifying the optimal solution for your application.



Engineered Performance

11122 West Little York • Houston, Texas 77041

Tel: 713-466-3552 • Fax: 713-896-7386

www.norriseal.com

Due to the continuous improvement program at Norriseal, specifications and/or prices are subject to change without notice or obligation. All other trademarks contained herein are the property of their respective owners.

© 2008 Norriseal, A Dover Company

6300-0608T