

Series 1001, 1001A and 1001XL Level Controllers

Proven Performers:

Versatile designs with no-bleed, forced-balanced operation



Series
1001



Series
1001A

Norriseal has been a leader in providing quality level measurement devices to the petroleum market for over 55 years. In addition to the petroleum market, Norriseal level products serve the marine, steel, and industrial markets.

This brochure describes the Series 1001, the 1001A, and the 1001XL Liquid Level Controllers. The Series 1001 and 1001A can be right-hand or left-hand mounted while the 1001XL is used where back-mounting is preferred.

Series 1001

The economical Series 1001 Level Controller uses a non-weatherproof case/cover.

Series 1001A

The Series 1001A Level Controller uses a weather-resistant sealed case and a manifold-style pilot assembly

Series 1001XL

The Series 1001XL Level Controller offers the features of a Series 1001A, but with a back-mount connection.

Features

- **No-bleed Pilots.** The pneumatic controller can be equipped with one of three types of no-bleed pilots: a snap pilot, throttling pilot, or patented Envirosave™ pilot.
- **Removable Door.** The controller door can only be removed after opening 90°. This feature prevents the door from vibrating loose while in the closed position. A lever latch keeps a positive engagement between the case and the door.
- **Weather-resistant Sealed Case (1001A & 1001XL).** An O-ring gasket seals internals from outside weather and allows the harmful exhaust gases to be vented to a remote area by tubing the vent connection to an exhaust manifold.
- **Built-In Filter.** A built-in 40-micron stainless steel filter in the gas supply connection reduces required maintenance of the controller's pilot.

Contents

- 2 Design
- 3 Principle of Operation
- 4 Performance Characteristics
- 5 Materials
- 6 How to Order
- 7 Model Code: Level Controllers
- 8 Dimensions
- 10 Vertical Chambers
- 12 Domes and Horizontal Chambers
- 13 Model Code: Vertical Chambers and Domes
- 14 Model Code: Horizontal Chambers
- 15 Applications

NORRIS
PRODUCTION SOLUTIONS
A DOVER COMPANY

NORRISSEAL™
A DOVER COMPANY

*Engineered
Performance*

Features (continued)

- **Interface Control.** A wide spring range makes the control of a liquid interface possible with the standard displacer.
- **Marine Service.** Stainless steel internals are available.
- **Field-Reversible Action.** This adjustment determines whether rising liquid level will increase or decrease pilot output.
- **Right- or Left-Hand Mount (1001 & 1001A).** The controller may be changed for right-hand or left-hand mount in the field without additional parts.

Design

Snap Pilot

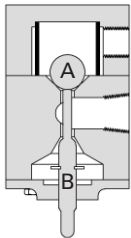

The pilot is comprised of two valves – one to admit pilot pressure, and one to exhaust pressure.

Ball "A" controls the flow of gas into the pilot and is held closed with force exerted by supply pressure on the seating area of the ball.

Snap Pilot When the force transmitted to thrust pin "B" is sufficient to overcome the force holding Ball "A" seated, "A" snaps upward allowing gas to flow past "A" and out the side port of the pilot.

The spherical end of thrust pin "B" closes the exhaust port the instant ball "A" snaps upward. The exhaust port seating area is smaller than the seating area of the supply port; therefore, the push rod must remain seated against supply pressure until force on the rod diminishes.

A simultaneous action occurs as force is removed from thrust pin "B". Pilot pressure opens the exhaust port by unseating the push rod, and supply pressure forces ball "A" to close the supply port. The difference in seating area gives this pilot Snap-Action.

Throttling Pilot

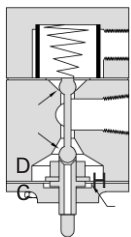

Throttling Pilot

Two valves are used to admit and exhaust pressure. A diaphragm "E" used in cooperation with the valves creates a Force-Balance Pilot.

The pilot output pressure acts upon the diaphragm so that the diaphragm pushes back with the same force being applied by the push rod. These balanced forces are the reason for the term "Force-Balance."

- **Electric Controller.** This option utilizes a standard electric switch; SPDT or DPDT.
- **Split Displacer.** For liquid dump spans greater than the standard displacers can provide, a split displacer can give dump spans up to 70 feet in length.
- **NACE.** All controllers can be configured to meet NACE MR0175-2002 specifications.

The throttle pilot works in the same manner as the snap pilot except the output pressure is proportioned to the amount of force applied to the push rod. More force on the rod produces a proportionate increase in pilot pressure.

When the push rod force changes, the pilot seeks a new balance point by either exhausting the output loading at valve "C" or unseating valve "D" to increase output loading. Instrument gas does not flow while the pilot is in balance.

Envirosave™ Pilot

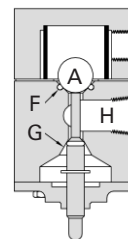

Envirosave™ Pilot

This patented pilot works identically to the snap pilot. The difference between the two is the O-ring seals "F" and "G," which give a positive seal to eliminate leakage and prevent fugitive emissions. The EPA has independently measured the Envirosave™ pilot to have a zero CFH consumption rate.*

Electric Level Switch

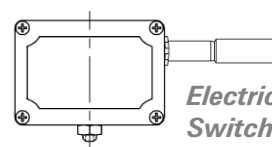

The electric level switch uses the force balance principle to open and close an electrical switch in response to rising or falling levels. Two standard switches are available, single pole double throw (SPDT) or double pole double throw (DPDT), both with explosion-proof enclosure.

* United States of America. Air and Radiation. Environmental Protection Agency. Lessons Learned From Natural Gas Star Partners: Options for Reducing Methane Emissions From Pneumatic Devices in the Natural Gas Industry. Appendix A. Washington, DC, 2003.

Force Balance Principle

Theory of Operation

The operation of the Series 1001, 1001A, and 1001XL Level Controllers is based on the Force Balance Principle. The **Force Balance Principle** states when an object is submerged in a liquid, it creates a buoyant force that is proportional to the weight of the liquid displaced. A Norriseal level controller uses a spring to balance the weight of a displacement-type element (displacer), eliminating the need for custom-weighted displacers and floats. As the displacer is immersed into the liquid, the amount of force available is proportional to the weight of the liquid displaced. The result of this force is transmitted to the controller by a rotational movement of the shaft. This rotational movement causes the fulcrum and lever (flapper bar) to push up the pilot thrust pin. The amount of force is proportional to the level on the displacer, creating a desired output signal. This desired output signal can be a pneumatic on/off signal using a snap pilot, a pneumatic modulating signal using a throttle pilot, or an electrical SPDT or DPDT signal by using an electric micro switch.

Controller Action

Controller action is "Direct Acting" when the output signal increases as the liquid level rises on the displacer. In "Reverse Acting," the output signal decreases as the liquid level increases on the displacer.

Proportional Band

Proportional Band or Span is the ratio of the displacer length used versus the total length of the displacer to achieve a desired output signal. For on/off control, the snap pilot output is equal to the supply pressure over the span of the controller. The span can be changed by sliding the fulcrum on the lever. Moving the fulcrum away from the pilot thrust pin increases the span, and moving the fulcrum towards the pilot decreases the span. For throttling control, the output will vary over the proportional band.

Function of the Adjustable Spring

Not only does the spring balance the weight of the displacer, it can also be adjusted to shift the setpoint on the displacer. With spring force held constant, a higher liquid level on the displacer produces a larger force available to the pilot. When the spring force is reduced by decompressing the spring, a higher liquid level on the displacer is required to produce the same force as before. Increasing the spring force by compressing the spring requires a lower liquid level for the

same force. Thus, increasing/decreasing the spring force will change the setpoint accordingly.

The spring compression can be reduced further to a position where a hydrocarbon liquid level will not produce enough force to produce an output from the pilot. This makes the control of a **liquid interface** possible with the standard displacer. After the spring is adjusted so the lighter liquid will not operate the control, there is still adequate spring force in reserve for the liquid level of heavier liquid to provide enough force to actuate the pilot.

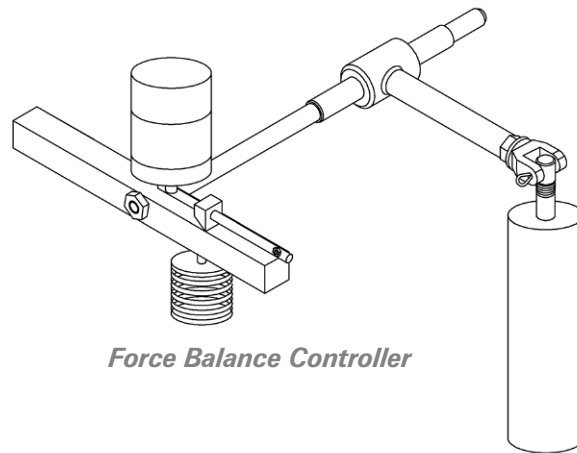

Force Balance Controller

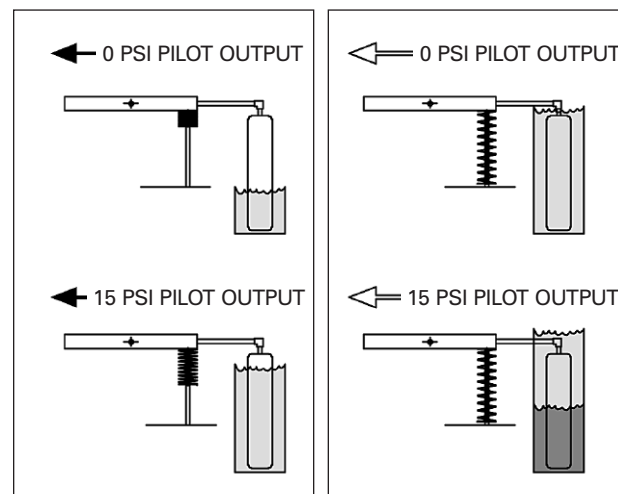

Top-level control

Liquid interface control

Performance Characteristics

PNEUMATIC PILOTS

PNEUMATIC PILOTS	
Output	
Proportional, throttle	3–15 psig, 6–30 psig
Differential gap, snap	0–20 psig, 0–30 psig
Differential gap, Envirosave™	0–20 psig, 0–30 psig
Supply Pressure Requirement	
3–15 psig, 0–20 psig	20–30 psig (min.)
6–30 psig, 0–30 psig	35–40 psig (min.)
0–50 psig	60 psig (max.)
0–100 psig	100 psig (max.)
Supply and Output Connection	¼ inch NPT Female
Ambient Temperature	-40° to 180°F (-40° to 82°C) -40 to 275°F (High temp) (-40 to 135°C)
Pilot Flow Capacity	
Throttle C _v	0.394
Snap C _v	0.282
Envirosave™ C _v	0.282
Proportional Band Adjustment (Recommended adjustment for a full output pressure change over a percent of sensing element)	
Throttle	20–150%
Snap	7–55%
Envirosave™	7–55%

GENERAL

Repeatability	1.0% of output span
Dead Band	5.0% of input span
Linearity	1.75% of output span
Ambient Temperature Effect on Setpoint	1.0% @ -40°F (-40°C) 3.0% @ +170°F (77°C)
Mechanical Disturbance Effects on Setpoint	1.0%
Specific Gravity	
Interface detection	0.035
Top level range	0.35 to 2.00
Temperature Limits Body process temperature (dependent on material selection)	-70° to +600°F (-57° to 316°C)
Process Pressure Rating	
Beveled - butt weld	To 6000 psig
Threaded (NPT)	To 6000 psig
Grooved	To 2500 psig
Flanged (RF & RTJ)	150 thru 2500 ANSI Class
Union w/sight glass	To 1500 psig
Ambient Temperature (A case extension is used for extreme temperatures or when body insulation is used.)	-40 to 160°F (-40° to 71°C)

ELECTRIC ON/OFF SWITCH

Output	
Proportional band adjustment (Electric – micro switch)	
SPDT	7–55%
DPDT	20–150%
Switch Ratings	
SPDT	15 amps at 125, 250, or 480 V.A.C.
DPDT	10 amps at 125 V.A.C.
Certifications	
Explosion proof switch	UL and CSA listed Class I, Div. 1, Groups C&D Class II, Div. 1, Groups E, F, &G

PNEUMATIC PILOTS

Body	
Throttle	Aluminum w/Aluminum Seat
Snap	Aluminum w/Aluminum Seat
Envirosave™	Aluminum w/Elastomeric Seat
Gasket/diaphragm	Nitrile
Internal Valving	Nylon
Filter Element	40 Micron SST
Screws & Nuts	SST

ELECTRIC ON/OFF SWITCH

Micro-Switch Enclosure	Cast aluminum
Junction Box	Cast aluminum

GENERAL

Body - LLC	
1001/1001A	ASTM A696/A105 -20 to +600°F (-29 to +316C°) ASTM A276/A182 -70 to +600°F (-57 to +316C°) ASTM A351 CF8M/A182 -70 to +600°F (-57 to +316C°)
1001XL	ASTM A216 WCC/A105 -20 to +600°F (-29 to +316C°) ASTM A216 LCC -50 to +600°F (-46 to +316C°) ASTM A351 CF8M/A182 -70 to +600°F (-57 to +316C°)
Hammer Nut (where applicable)	ASTM A105
Sight Glass (For special DU/AU union body)	Acrylic -20 to +200°F (-29 to +93C°) Pyrex -20 to +400°F (-29 to +204C°)
Displacers	PVC -20 to +140°F (-29 to +60C°) Acrylic -20 to +200°F (-29 to +93C°) 316 SST -70 to +600°F (-57 to +316C°)
Displacer Arm	316 SST
Vertical Hanger (swivel for vertical displacer position)	316 SST
Chain	304 SST (for vertical extension and/or split displacer)
Shaft	316 SST -70 to +600°F (-57 to +316C°)
Bearing Blocks	316 SST -70 to +600°F (-57 to +316C°)
Bearings	440 SST -70 to +600°F (-57 to +316C°)
Shaft Seals	Nitrile -20 to +180°F (-29 to +82C°) Nitrile lo-temp -50 to +180°F (-46 to +82C°) Fluorocarbon -20 to +400°F (-29 to +204C°) Aflas -20 to +600°F (-29 to +316C°) EPR -50 to +250°F (-46 to +121C°)
Case & Cover	Die cast chromated aluminum with powder coat
Supply and Output Gauges	Brass (standard) 316 SST Brass liquid fill 316 SST liquid fill
Torque Bar	Aluminum (standard) 303 SST
Flapper Bar	303 SST
Spring Adjusting Knob	Aluminum (standard) 303 SST
Fulcrum	Nylon w/SST screw
Balancing Spring	Light - SST w/green marking Medium - SST w/no marking Heavy - SST w/yellow marking Extra Heavy - SST w/red marking

Note:
Materials that are certified compatible for NACE service are available upon request.

Determine the model number. This specifies series and connection size; pilot type; left, right or back mount; pilot action; seals; and service condition.

Required Application Information:

- A. Fluid media
- B. Process temperature (maximum and minimum)
- C. Process pressure
- D. Vessel size and diameter (distance of connection from bottom of vessel, any obstructions that may hinder performance)
- E. Body connection type, size, and rating
- F. Displacer position (vertical or horizontal)
- G. Controller mount (right or left) if applicable
- H. Pilot action
- I. Area electrical classification if applicable
- J. Top level or interface

Electric Level Switch

The electric level switch uses the force balance principle to apply force to a standard Micro-switch.

Two standard switches are available, both with explosion-proof enclosures: single pole double throw (SPDT) or double pole double throw (DPDT). Rating for SPDT switch is 15 amps at 125, 250, or 480 volts A.C. The DPDT switch rating is 10 amps at 125 or 250 volts A.C.

Right-Hand Mount vs. Left-Hand Mount

The Series 1001 and Series 1001A can be configured as right-hand mount or left-hand mount. The orientation of the displacer to the controller (while facing the front side of the controller) designates the mounting style. The mounting can be adjusted in the field. The Series 1001XL back-mount controller is utilized when neither right-hand or left-hand mounts are practical.

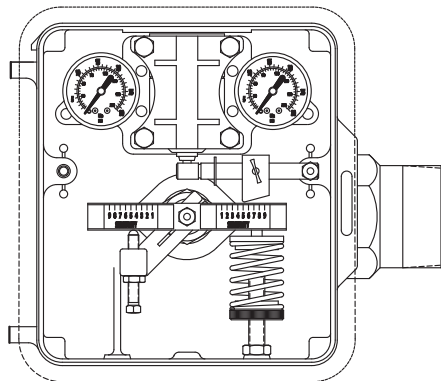

Right-Hand Mount

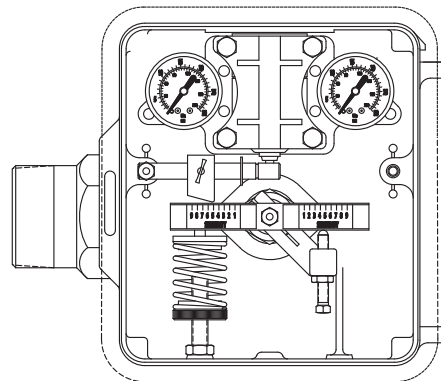

Left-Hand Mount

2SM 60-SRDA-BG

END CONNECTIONS	
Size	Code
1.50"	15
2.00"	2
3.00"	3
4.00"	4
6.00"	6

END CONNECTIONS		
Type	Code	
Beveled Slip-on	BS	
Beveled Butt Weld Sch 40	B4	
Beveled Butt Weld Sch 80	B8	
Beveled Butt Weld Sch 160	B1	
Beveled Butt Weld Sch XXH	BX	
Grooved	GV	
Flanged	Raised Face	RF
	Ring Type Joint	RJ
	Special 4 Bolt	SF
Screwed Male NPT	SM	
Acme Union	AU	
Dover Union	DU	

PRESSURE RATING		
ANSI	Rating*	Code
150	285	02
300	740	07
600	1480	14
	1500	15
	2000	20
900	2200	21
	3000	30
1500	3750	36
2500	6170	60

*Unit pressure rating subject to selection of displacer (reference displacer chart below).

MATERIAL: BODY/SHAFT/BLOCK			
Body	Shaft	Bearing Block	Code
A696 CS or WCC	316	316	-
A696 CS (NACE)	316	316	N
316 (NACE)	316	316	R
316	316	316	S

PILOT MODE	
Mode Type	Code
Electric DPDT (Ex-Proof)	D
Electric SPDT (Ex-Proof)	E
Envirosave™ Snap (On/Off)	B
Pneumatic Snap (On/Off)	S
Pneumatic Throttle (Modulating)	T

ENCLOSURE	
Code	Type
A	Standard Case (1001 Only)
G	Weather-resistant Case Only
H	Weather-resistant Case and Piped Exhaust
J	Weather-resistant Case, Piped Exhaust and Special Marine Internals
K	Weather-resistant Case and Special Marine Internals

SERVICE CONDITION	
Code	Service
B	Standard
C	Vibration

PRESSURE GAUGES	
Code	Type
-	Bronze 0-60 psi (std)
K	316 SST 0-60 psi (1001A/1001XL)
M	Liquid Filled 0-60 psi (1001A/1001XL)

SEAL MATERIAL		
CODE	Max.Temp. (°F)**	O-Ring
A	180	Buna
E	250	EPR
F	400	Viton
S	400	Aflas

**Unit temperature rating subject to selection of displacer. See displacer chart.

PILOT ACTION	
Code	Pilot Action
D	Direct Acting
R	Reverse Acting

MOUNTING CASE	
Code	Type Mounting
B	Back XL Only
L	Left Hand
R	Right Hand

DISPLACER CHART DISPLACER TEMPERATURE/PRESSURE RATING		
Material	Max Temp °F	Max Pressure (PSIG)
PVC	-20 to 140	6170
Acrylic	-20 to 200	6170
SST-2	-70 to 600	2000*

* Higher pressure SST displacers are available.

Dimensions

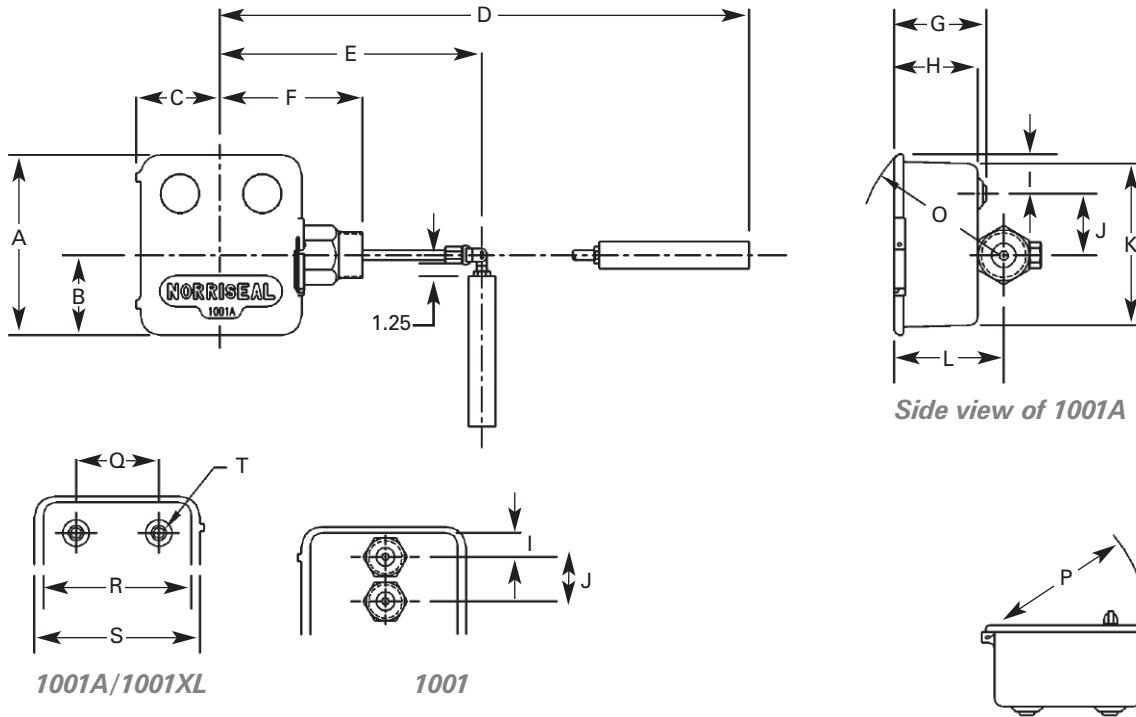

MODEL			
	1001	1001A	1001XL
A	7.68	8.74	8.74
B	3.00	3.85	3.00
C	4.09	4.13	4.13
D	24.43*	24.43*	24.44*
E	13.67*	13.67*	13.67*
F	*	*	*
G	3.12	4.36	4.36
H	2.75	3.95	3.95
I	0.90	1.90	1.90
J	1.00	2.98	2.98
K	7.68	7.98	7.98
L	4.00	5.19	–
O	6.00	7.13	–
P	7.75	7.85	7.85
Q	–	4.00	4.00
R	–	7.06	7.06
S	–	8.01	8.01
T	¼ NPT	¼ NPT	¼ NPT
U	4.75	4.87	5.16

* See page 9 for "F" dimension for different type of connections

* Using standard 1.88 dia. X 12 inch displacer and 12.5 inch displacer arm. Length is dependent upon displacer arm and displacer.

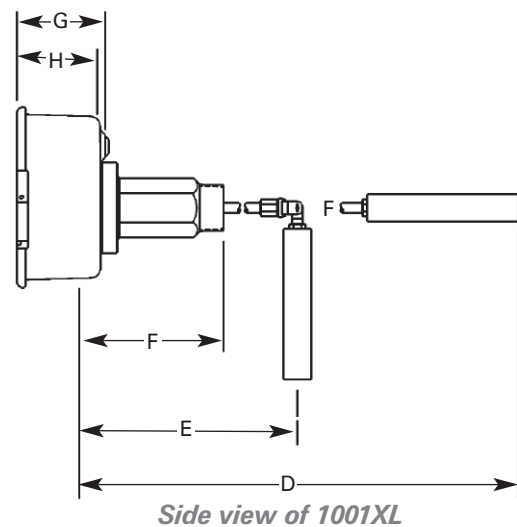

DIMENSIONS "F"

Body Styles X	Body Size			
	2.00	3.00	4.00	6.00
Beveled B/W SCH 40	6.00	–	–	–
SCH 80	6.00	–	–	–
SCH XXH	6.00	–	–	–
Beveled Slip-on	6.00	–	–	–
Screwed Male NPT	6.00	–	–	–
Grooved	6.00	6.88	6.94	7.00
Flanged - 4-bolt -special	6.88	–	–	–
-150 RF	6.50	6.56	6.56	8.75
-300 RF	6.81	6.75	6.88	9.19
-300 RTJ	7.06	7.00	7.25	9.25
-600 RF	7.19	7.13	7.50	10.13
-600 RTJ	7.25	7.31	7.56	10.19
-900 RF	8.00	9.63	10.13	10.56
-900 RTJ	8.06	9.69	10.19	10.63
-1500 RF	8.00	10.25	10.63	11.88
-1500 RTJ	8.06	10.31	10.69	11.94
-2500 RF	9.13	11.00	11.75	13.50
-2500 RTJ	9.19	11.13	11.94	13.75

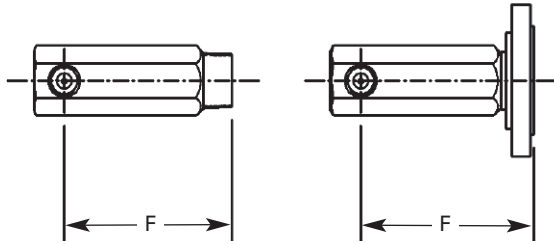

Series 1001 and 1001A

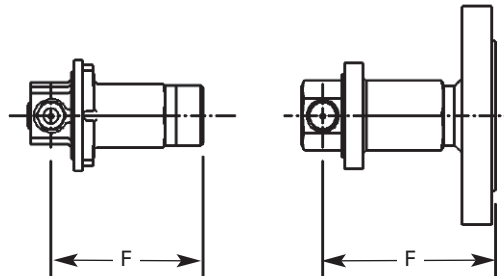

Series 1001XL

WEIGHTS

Body Styles X	Body Size			
	2.00	3.00	4.00	6.00
Beveled B/W SCH 40	17	NA	NA	NA
SCH 80	17	NA	NA	NA
SCH XXH	17	NA	NA	NA
Beveled Slip-on	18	NA	NA	NA
Screwed Male NPT	18	NA	NA	NA
Grooved	8	19	20	
Flanged - 4-bolt -special	26	NA	NA	
-150 RF	25	30	34	
-300 RF	27	35	45	
-300 RTJ	27	35	45	
-600 RF	29	37	55	
-600 RTJ	29	37	55	
-900 RF	40	51	75	
-900 RTJ	40	51	75	
-1500 RF	45	72	95	
-1500 RTJ	45	72	95	
-2500 RF	61	110	150	
-2500 RTJ	61	110	150	

Weights are for 1001. For 1001A add 1 lb. and for 1001XL add 2 lb.

Series 1006 Vertical Chambers

The Series 1001 and Series 1001A can be externally mounted using our Series 1006 vertical or horizontal external chambers. These external chambers provide more stable operation for vessels with internal obstruction or considerable internal turbulence.

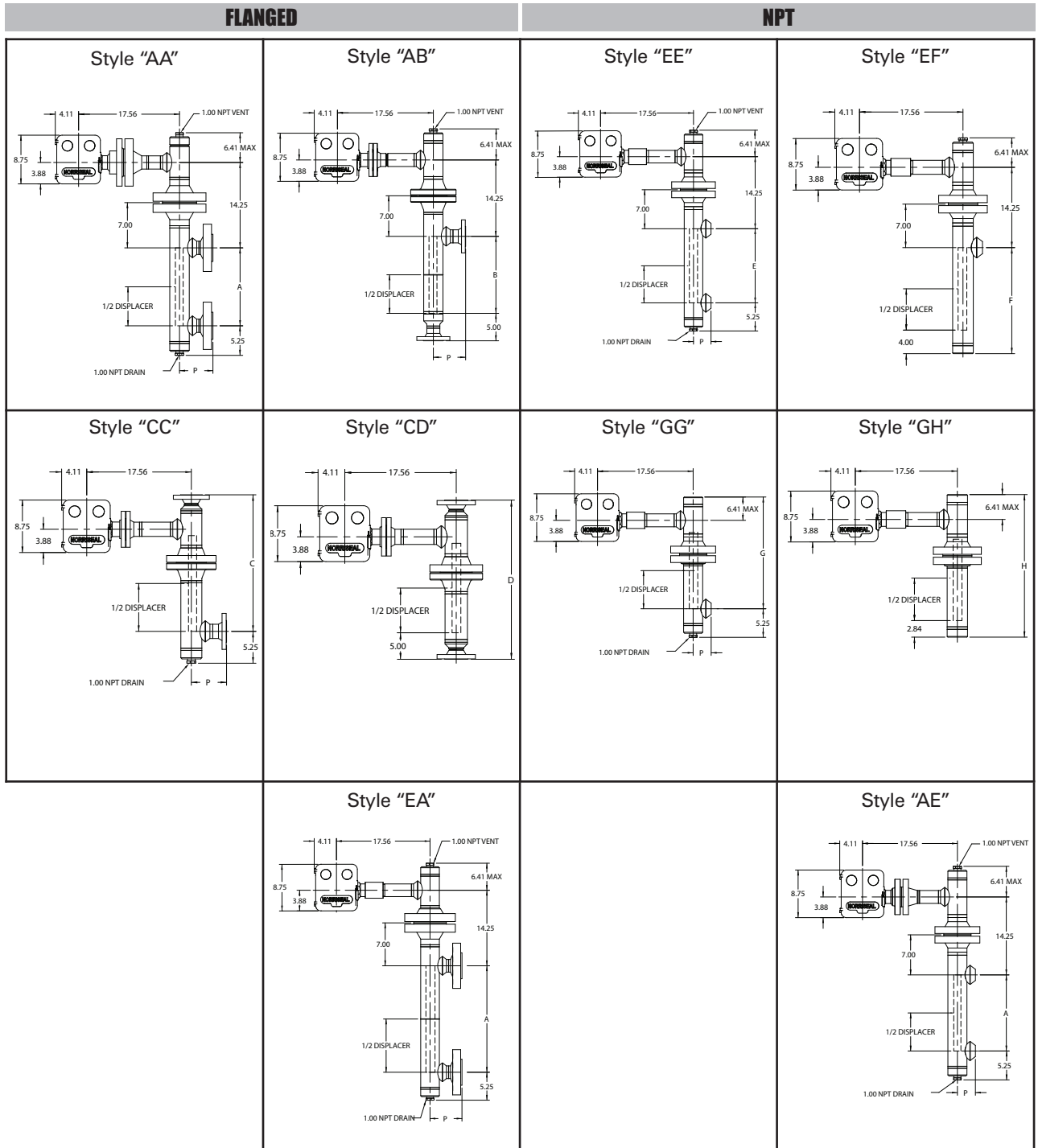

Other process connections available

PROCESS CONNECTIONS DIMENSIONS (INCHES)

Type	Style	Displacer	Dim**	Dim
Flanged	AA	14	A	14
		32		32
	AB	14	B	19
		32		37
	AE	14	E	14
		32		32
	CC	14	C	21
		32		39
	CD	14	D	26
		32		44
NPT	EA	14	A	14
		32		32
	EE	14	E	14
		32		32
	EF	14	F	18
		32		36
	GG	14	G	19
		32		37
	GH	14	H	23
		32		41

PROCESS CONNECTIONS (INCHES)

ANSI Class		DIM	150	300	600
3.00 x 1.50 flg	RF	P	5.62	5.88	6.19
	RTJ	P	5.88	5.62	6.19
3.00 x 2.0 flg	RF	P	5.88	6.12	6.50
	RTJ	P	6.12	6.44	6.56
4.00 x 1.50 flg	RF	P	6.12	6.38	6.69
	RTJ	P	6.38	6.62	6.69
4.00 x 2.0 flg	RF	P	6.38	6.62	7.00
	RTJ	P	6.62	6.94	7.06

NPT Size	DIM	1.0 in.	1.5 in.	2.0 in
3.00 x NPT	P	3.12	3.19	3.31
4.00 x NPT	P	3.62	3.69	3.81

*Other displacer lengths available on request.

**Charted dimensions are for process connecting piping.
All other dimensions may vary with respect to flange size and ANSI class.

Position of Process Connections

The following diagram illustrates the location of the process connections and level controller relative to Position 1 (P1) which is zero. Refer to Model Code, Position Process Connection on page 13.

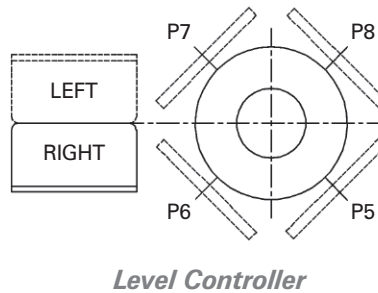
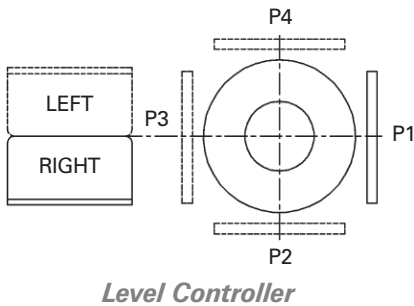

Series 1006D Dome

To specify a dome only (this is the top of the vertical chamber), add a suffix letter 'D' to the end of the Series Number. Refer to the Model Code, Vertical Dome Style on page 13.

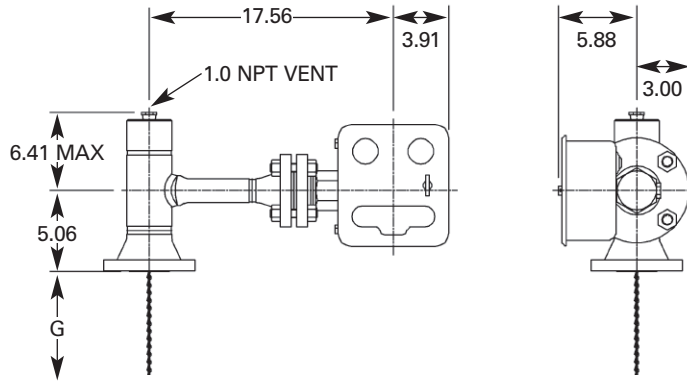

Series 1006 Horizontal Chamber

(For Model Code, refer to page 14)

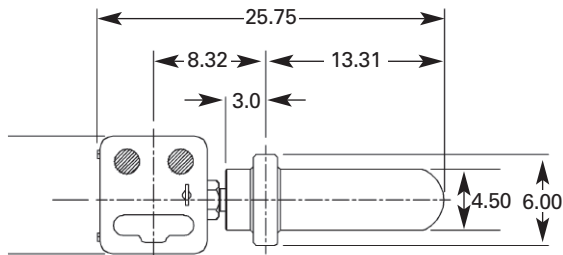

*Typical NPT Level Controller & Chamber
(Flanged configuration available)*

The following model codes apply to the Series 1006 Vertical Chamber and Dome and to the Series 1006D only.

3AA14-20RF 14-PI

CHAMBER/DOME PIPE SIZE	
Description	Code
3.00" (Std.)	3
4.00"	4

VERTICAL DOME STYLE	
Description	Code
Flanged LLC w/NPT Vent	A
Flanged LLC w/top Flanged Process Conn	C
Screwed LLC w/NPT Vent	E
Screwed LLC w/Top NPT Process Conn	G

VERTICAL CHAMBER STYLE			
Type Process Connection	Type Level Control Connection	Process Connection Mounting Style	Code
Flanged	See Dome	Side Top-Side Btm	A
Flanged	See Dome	Side Top-Btm	B
Flanged	See Dome	None-Side Btm	C
Flanged	See Dome	None-Btm	D
Screwed	See Dome	Side Top-Side Btm	E
Screwed	See Dome	Side Top-Btm	F
Screwed	See Dome	None-Side Btm	G
Screwed	See Dome	None-Btm	H
1006 Dome Only			O

DISPLACER LENGTH	
Description	Code
14.00 Inch	14
32.00 Inch	32
48.00 Inch	48
60.00 Inch	60
Dome Only	0

DOME/CHAMBER MATERIAL	
Description	Code
Carbon Steel A105	-
Carbon Steel - NACE, A333/A350 -50°F	L
Carbon Steel - NACE, A105/A106	N
316L Stainless Steel - X-Ray NACE	R
316L NACE	W
316 Stainless Steel	S

PROCESS CONNECTION	
Description	Code
1.00 Inch	10
1.50 Inch	15
2.00 Inch	20
2.50 Inch	25
3.00 Inch	30
4.00 Inch	40

POSITION PROCESS CONNECTION	
Code	Description
P1	0 Degrees w/LLC at 180 Degrees
P2	90 Degrees w/LLC at 180 Degrees
P3	180 Degrees w/LLC at 180 Degrees
P4	270 Degrees w/LLC at 180 Degrees
P5	45 Degrees w/LLC at 180 Degrees
P6	135 Degrees w/LLC at 180 Degrees
P7	225 Degrees w/LLC at 180 Degrees
P8	315 Degrees w/LLC at 180 Degrees

STUD & GASKET MATERIAL			
Code	Stud/Nut	Gasket	
		RF or FF	RJ
-	ASTM A193-B7/ ASTM A194-2H	316L/GRF CSTL GR	CSTL Solid
A	ASTM A193-B8M/ ASTM A194-8M	316L/GRF CSTL GR	316 SS Solid
B	ASTM A193-B7/ ASTM A194-2H	316L/GRF 316SS GR	316 SS Solid
C	ASTM A193-B7/ ASTM A194-2H	INC/GRF CSTL GR	-
D	ASTM A193-B8M/ ASTM A194-SS8M	316L/GRF 316SS GR	316 SS Solid
L	ASTM A193-B7M/ ASTM A194-2HM	INC/GRF 316SS GR	316 SS Solid
M	ASTM B164/ Monel 400	MON/GRF 316SS GR	-

RATING PROCESS CONNECTION		
Code	Description	
02	Flanged (ANSI)	150
07		300
14		600
21		900
36		1500
14	NPT (WP)	1480

- NOTE:
1. Flanged - LLC & Dome/Chamber connection rated same as Process Connection. Except - ANSI 150 Class Dome/Chamber Connection is ANSI 300.
 2. Threaded-Dome/Chamber connection is ANSI 600 class; higher pressure classes available.

TYPE PROCESS CONNECTION	
Code	Description
RF	Flanged - RF (Raised Face)
RJ	Flanged - RJ (Ring Type Joint)
SC	Screwed Female
SM	Screwed Male

NOTE:
Specify when Gauge Glass connections are required. Give size, position, and center-to-center dimensions.

Model Code: Horizontal Chambers

CHAMBER PIPE SIZE	
Description	Code
4.00"	4.0

RATING PROCESS CONNECTION		
Code	Description	
02	Flanged (ANSI)	150
07		300
14		600
21		900
36		1500
30	NPT (WP)	3000

4 V 12-20 RF 14

HORIZONTAL CHAMBER STYLE			
Type Process Connection	Type Level Control Connection	Process Connection Mounting Style	Code
Screwed	Flanged	Top-Bottom	L
Flanged	Screwed	Top-Bottom	M
Flanged	Flanged	Top-Bottom	N
Socket Weld	Flanged	Top-Bottom	S
Screwed	Screwed	Top-Bottom	V
Socket Weld	Screwed	Top-Bottom	X
Buttweld	Flanged	Top-Bottom	Y
Buttweld	Screwed	Top-Bottom	Z

TYPE PROCESS CONNECTION	
Code	Description
RF	Flanged - RF (Raised Face)
RJ	Flanged - RJ (Ring Type Joint)
SC	Screwed Female
SM	Screwed Male

PROCESS CONNECTION	
Code	Description
10	1.00 Inch
15	1.50 Inch
20	2.00 Inch

DISPLACER LENGTH	
Description	Code
12.00 Inch	12
Specify	XX

CHAMBER MATERIAL	
Description	Code
Carbon Steel A105/A106	-
Carbon Steel A105/A106 Except Domestic Material	D
Carbon Steel - NACE, A333/A350 -50°F	L
Carbon Steel - NACE, A105/A106	N
316 L Stainless Steel - X-Ray NACE	W
316 Stainless Steel	S

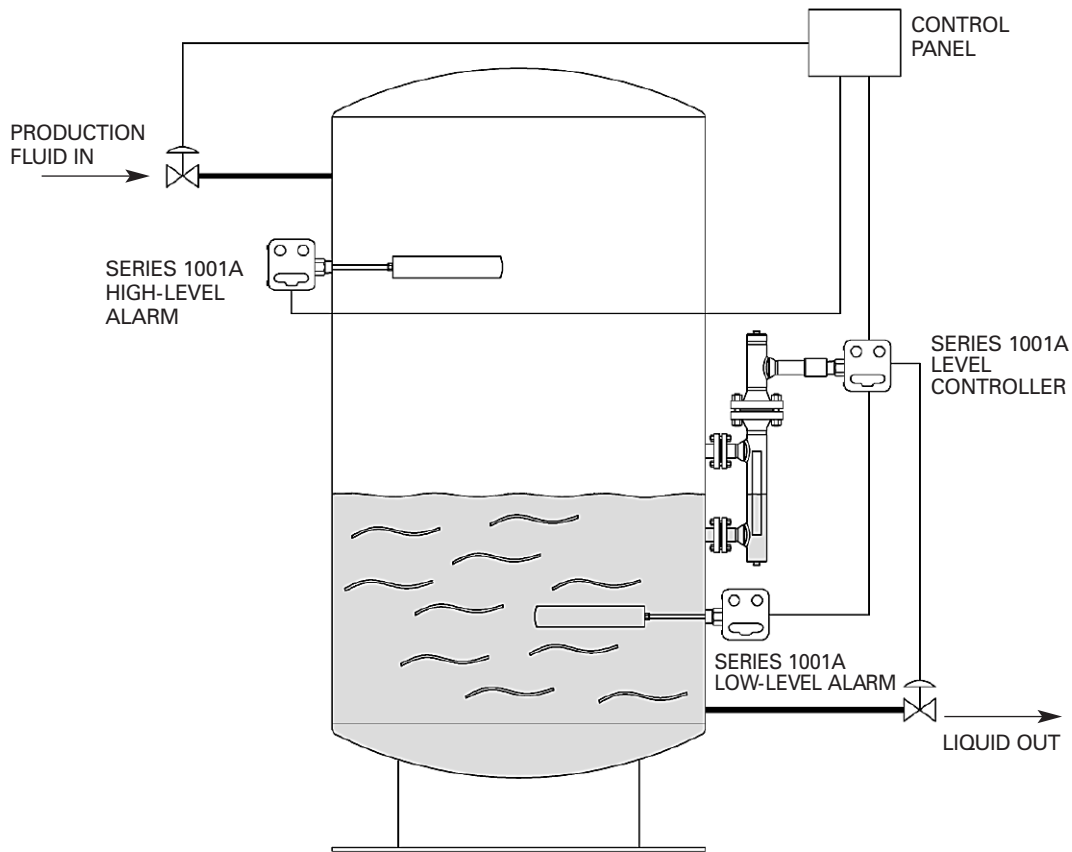

Common Applications

1. Custody Transfer Measurement Systems
2. Separators
3. Dehydrators
4. Heater Treaters
5. Well Test Systems
6. Interface Detection
7. Compressor Scrubbers
8. Offshore Production Facilities

Why you can depend on genuine Norriseal products

- In-house engineering and technical support
- In-depth applications experience
- Award-winning innovation and ongoing product development
- ISO 9001-certified manufacturing
- Over five decades of industry service
- Compliance with all industry standards and specifications
- Responsive service and prompt delivery
- Field support available worldwide

Please contact your Norriseal representative for more details and assistance in specifying the optimal solution for your application.



Engineered Performance

11122 West Little York • Houston, Texas 77041

Tel: 713-466-3552 • Fax: 713-896-7386

www.norriseal.com

Due to the continuous improvement program at Norriseal, specifications and/or prices are subject to change without notice or obligation. Envirosave is a mark of Norriseal, A Dover Company. All other trademarks contained herein are the property of their respective owners.

© 2011 Norriseal, A Dover Company

0LLC-1211T