

# Series 2200 and 2220 Control Valves

## Space-Saving Solution:

Yokeless design fits tight separator and scrubber applications



### *Norriseal Series 2200 and 2220 control valves*

*have been the standard for controlling fluids in the oil and gas industry since 1966. The hammer nut entry into the valve body allows quick access for trim inspection.*

*Both Series 2200 and 2220 valves can be furnished with a variety of trims and end connections (see table 7 on page 4 and table 5 on page 3).*

*The Series 2200 has an open yoke which allows for the mounting of positioners, limit switches and other devices. It is also used in applications that require an exposed stem for accurate travel indication.*

*The yoke allows the valve to be used for higher temperature ranges.*

*The Series 2220 is the close-coupled or yokeless, space saving version of the Series 2200. This series is ideal for controlling liquids on compressor scrubbers and housed production separators where space is at a premium.*

## Features

- Patented spherical plug and matching seat gives precision seating alignment
- Two types of throttling trim for precision control: modified percentage and equal percentage
- Hammer nut has extra thread engagement on the valve body to release any pressure within the body and allow safe removal of the bonnet/actuator during disassembly
- Integral flange is provided on the bonnet to secure the hammer nut/bonnet to the valve body, improving safety when used in a corrosive atmosphere
- Carbide, ceramic, alloy 6 and soft seats with high-density materials are available, as well as seal materials for corrosion and high/low temperatures; other materials are available for NACE applications

## Contents

- 2** Body Styles
- 2** Valve Dimensions
- 3** Specifications
- 4** Valve Trim
- 6** Actuators
- 7** How to Order
- 7** Model Code

**NORRIS**  
PRODUCTION SOLUTIONS

A DOVER COMPANY

**NORRISSEAL™**  
A DOVER COMPANY

**Engineered  
Performance**

# Body Styles and Dimensions

## Body Styles

### Globe, "T" Styles and Angle Bodies

The 1.00-inch comes in two styles: globe and T-body, allowing fluid to flow straight through the body in a globe pattern or angle flow pattern by repositioning the pipe plug (which comes in the bottom port) and replacing it in the upper port. Norriseal popularized the T-body in 1950 and it still is the most popular style in the industry.

The 2.00-inch body comes in two styles, globe and angle.

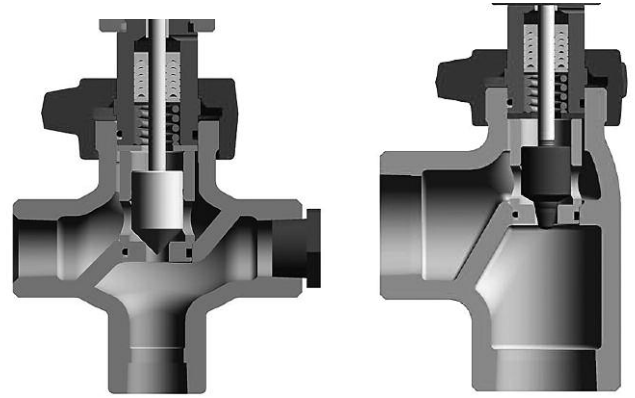

1.00-inch T-body plug for angle flow with quick opening carbide trim.

2.00-inch angle body with equal percentage 17-4 PH SST trim.

**TABLE 1: VALVE DIMENSIONS**

Body Size		Body Type	Face to Face "F"										"G"	
			ANSI Rating											
			150		300		600		900/1500		2500			
inches	mm	inches	mm	inches	mm	inches	mm	inches	mm	inches	mm	inches	mm	
1.00	25	NPT							6.25	159	6.25	159	4.88	124
		RF	7.25	184	7.75	197	8.25	210	9.38	238	11.38	289		
		RTJ	7.75	197	8.25	210	8.25	210	9.38	238	11.38	289		
2.00	50	NPT							7.50	191	7.50	191		
		RF	10.00	254	10.50	267	11.25	286	12.88	327	16.25	413		
		RTJ	10.50	267	11.13	283	11.38	289	13.00	330	16.48	418		

\* Angle 2.00 "screwed body not shown. "F" dimension = "F"/2.

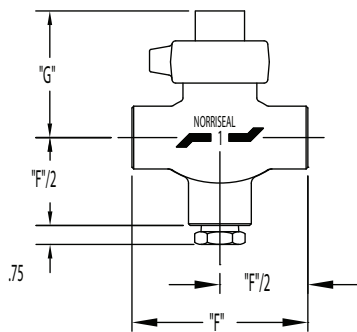

1.00" NPT Body

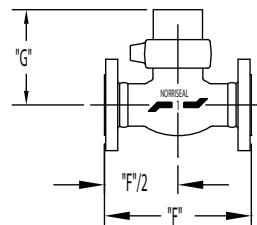

1.00" Globe Body

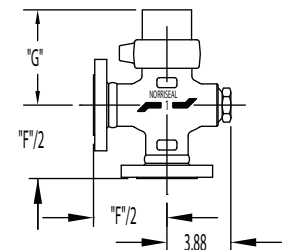

1.00" Angle Body

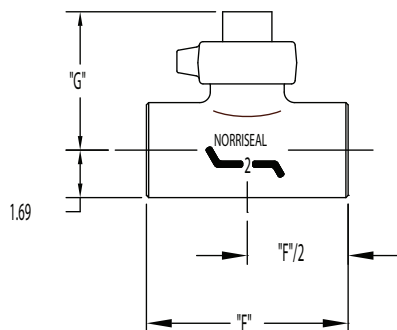

2.00" NPT Body

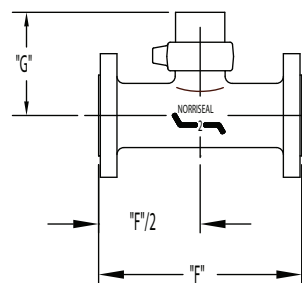

2.00" Globe Body

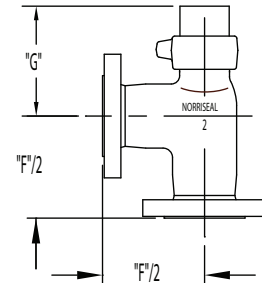

2.00" Angle Body

**TABLE 2: MATERIALS OF CONSTRUCTION**

Valve Component		
Body	ASTM A216 Gr. WCC ASTM A351 Gr. CF8M	ASTM A352 Gr. LCC ASTM A217 Gr. WC6
Bonnet	ASTM A696/C	316 SST
Hammer Nut	ASTM A105 ASTM A350 Gr. LF2	316 SST
Stem	303 SST Monel	17-4 PH SST 316 SST
Packing	TFE V Ring Viton/TFE	Fabric V Ring
Packing Spring	316 SST Mp-35-N	Inconel/600
Packing Washer	CSTL 316L SST	316 SST
Packing Retainer	Brass 316 SST	316L SST
O-Ring Valve	Nitrile Aflas EPR	Kalrez Viton HSN
Diaphragm	Buna/Nylon Neoprene/Nylon	Viton/Nylon
O-Ring Diaphragm	Nitrile EPDM	Viton HSN
Actuator Spring	Steel	On Application
Adjust. Screw	CSTL/PLtd.	316 SST
Diaphragm Housing	CSTL	
Diaphragm Plate	CSTL	
Travel Indicator	303 SST	
Actuator Pressure Connection Size – 1/4" – 18 NPT Thread		

**TABLE 3: OPERATING TEMPERATURE\***

2200/2220	Std. WCC Mtl.	-20 to 180°F (-29 to 82°C)
2200/2220	Std. LCC Mtl.	-40 to 180°F (-40 to 82°C)
2200	Opt. Mtl.	-50 to 400°F (-45 to 204°C)
2220	Opt. Mtl.	-50 to 300°F (-45 to 149°C)

\* Optional material built valves can cover high or low temperature ranges, but not necessarily both.

**TABLE 4: ACTUATOR**

Actuator Number	Maximum W. P.		Size/Eff. Area		Travel	
	psig	bar	sq. ins.	cm. sq.	ins.	mm
9	55	3.7	35	226	0.625	15.9
12	55	3.7	70	452	0.625	15.9

**TABLE 5: BODY END CONNECTIONS AND PRESSURE RATINGS\***

Body Size Inches mm	Pressure Rating		NPT	Butt Weld	Socket Weld	ASME Flanged RF and RTJ				Body Style
	psig	bar				150/300	600	900/1500	2500	
1.00 25	3750	259	X	X	X	X	X	X		Globe/"T"
1.00 25	6250	431	X	X	X				X	"T"
2.00 50	3750	259	X	X	X	X	X	X		Globe/Angle
2.00 50	6000	259	X	X	X				X	Globe/Angle

\* Pressure ratings are based on temperatures of -20 to 100° F (-29 to 38° C) with standard material. Consult factory for pressure ratings for temperatures other than those shown. (X) indicates end connections available.

**TABLE 6: 2200/2220 GLOBE & ANGLE BODY, MODIFIED PERCENTAGE, EQUAL PERCENTAGE & QUICK OPENING, UNBALANCED, PLUG CONTROL TRIMS**

Body Size		Trim Size		Flow Coefficient (C <sub>v</sub> ) Globe Body Valve Opening – Percent of Total Travel										Quick ^ Opening
				Modified Percentage (Flow Up)										(Flow Down)
Inches	mm	Inches	mm	10	20	30	40	50	60	70	80	90	100	100
1.00	25	0.25	6.4	.284	.506	.657	.767	.875	.989	1.10	1.20	1.32	1.43	1.68
		0.38	9.5	.311	.621	.942	1.28	1.64	2.07	2.51	2.93	3.35	3.70	3.82
		0.50	12.7	.557	1.11	1.68	2.26	2.92	3.62	4.30	4.98	5.43	5.60	5.60
		0.75	19.1	.752	1.57	2.43	3.42	4.58	6.08	7.93	9.71	10.6	11.0	11.6
		1.00	25.4	.983	2.01	3.40	6.12	8.90	11.7	13.5	14.4	15.1	15.4	15.4
2.00	50	0.25	6.4	.284	.506	.657	.767	.875	.989	1.10	1.20	1.32	1.43	1.68
		0.38	9.5	.311	.621	.942	1.28	1.64	2.07	2.51	2.93	3.35	3.70	3.75
		0.50	12.7	.592	1.17	1.76	2.34	2.95	3.70	4.57	5.50	5.95	6.08	6.08
		0.75	19.1	.882	1.76	2.76	3.82	5.05	6.57	8.49	10.8	12.2	12.9	13.0
		1.00	25.4	1.01	2.02	3.58	6.45	9.38	12.32	13.7	15.4	16.7	17.1	23.0

\* Consult factory for equal percentage and micro-groove trim values; ^ Angle body

**TABLE 7: PLUG TYPES AND SIZES**

Size		Quick Opening	Modified Percentage	Equal Percentage	Micro Groove
Inches	mm				
0.25	6.4	X	X	X	X
0.38	9.4	X	X	X	X
0.50	12.7	X	X	X	X
0.75	19.1	X	X	X	
1.00	25.4	X	X		

Note: (X) indicates sizes available

**TABLE 8: PLUG MATERIAL**

Standard	Optional
17-4 SST	316 SST
	Carbide
	Ceramic
	Alloy 6
	Teflon

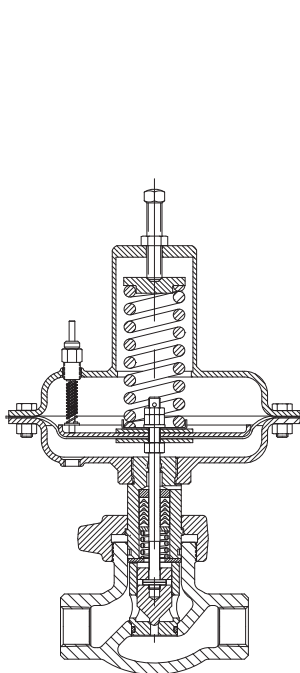

**Fig. 9. 1.00" Series 2220 valve with a no. 9 reverse (spring closing) actuator. Throttle trim, flow up.**

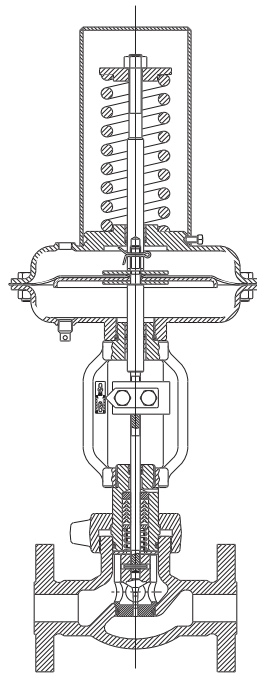

**Fig. 10. 1.00" Series 2200 valve with a no. 9 direct (spring opening) actuator. Throttle trim, flow up.**

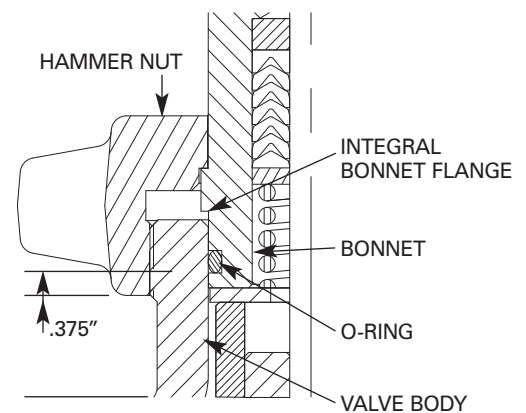

**Fig. 11. Hammer Nut/Bonnet Body Engagement**

**TABLE 9: MAXIMUM DIFFERENTIAL PRESSURE (3-15 PSI)**

Trim Size		Actuator Size	Gas Supply Pressure		Flow Under Seat				Flow Over Seat			
					Throttle				Quick Opening			
					Direct		Reverse		Direct		Reverse	
Inches	mm	Number	psig	bar	psig	bar	psig	bar	psig	bar	psig	bar
.25	6.4	9	20	1.4	2610	180	4750	327	6250	431	6250	431
			30	2.0	6250	431	6250	431	6250	431	6250	431
		12	20	1.4	6250	431	6250	431	6250	431	6250	431
			30	2.0	6250	431	6250	431	6250	431	6250	431
.38	9.5	9	20	1.4	1050	72	1975	136	6250	431	6250	431
			30	2.0	4220	291	5150	355	6250	431	6250	431
		12	20	1.4	3695	255	5550	383	6250	431	6250	431
			30	2.0	6250	431	6250	431	6250	431	6250	431
.50	12.7	9	20	1.4	530	36	1050	672	6250	431	6250	431
			30	2.0	2315	160	2850	197	6250	431	6250	431
		12	20	1.4	2015	139	3060	211	6250	431	6250	431
			30	2.0	5580	385	6250	431	6250	431	6250	431
.75	19.1	9	20	1.4	180	12	420	29	2400	166	1700	117
			30	2.0	975	67	1210	83	3460	239	1700	117
		12	20	1.4	840	58	1315	91	4520	312	2975	205
			30	2.0	2415	167	2900	200	6250	431	5090	351
1.00	25.4	9	20	1.4	70	5	205	14	1215	84	780	54
			30	2.0	515	35	650	45	1730	119	780	54
		12	20	1.4	440	30	710	49	2255	155	175	12
			30	2.0	1330	92	1600	110	3290	227	2330	161

**TABLE 10: MAXIMUM DIFFERENTIAL PRESSURE (6-30 PSI)**

Trim Size		Actuator Size	Gas Supply Pressure		Flow Under Seat				Flow Over Seat			
					Throttle				Quick Opening			
					Direct		Reverse		Direct		Reverse	
Inches	mm	Number	psig	bar	psig	bar	psig	bar	psig	bar	psig	bar
.25	6.4	9	33	2.3			6250	431	6250	431		
		12			6250	431	6250	431	6250	431	6250	431
.38	9.5	9	33	2.3			3300	228	6250	431		
		12			3955	273	5855	404	6250	431	6250	431
.50	12.7	9	33	2.3			1804	124	6250	431		
		12			2165	149	3200	221	6250	431	6250	431
.75	19.1	9	33	2.3			751	52	3165	218		
		12			905	62	1380	95	6250	431	285	20
1.0	25.4	9	33	2.3			393	27	1525	105		
		12			480	33	745	51	3600	248	175	12

**TABLE 11: SPRING DESCRIPTION**

Actuator Number	Throttle	Quick Opening	Range	Table No.
9		AA	3 – 11 psi	9
	NN		3 – 15 psi	9
	HA	HA	6 – 30 psi	10
12	HA	HA	3 – 15 psi	9
	WM	WM	6 – 30 psi	10

**TABLE 12: SHUTOFF CLASSIFICATION**

Metal Seats	ANSI Class IV (ANSI/FCI 70-2-1998) Leakage less than 0.01% of maximum valve capacity
Soft Seats	ANSI Class VI (ANSI/FCI 70-2-1998) Leakage less than one bubble per minute.

**TABLE 13: ACTUATOR DIMENSIONS**

Body Size		Actuator Number	Spring Description	A		B								Direct* Spring Cover	
				Actuator Diameter		Reverse				Direct					
Inches	mm			Inches	mm	2200		2220		2200		2220		Inches	mm
1.00	25	9	AA	9.5	241	15.38	391	9.75	248	15.88	403	10.25	260	5.50	140
2.00	50		NN, HA			17.13	435	11.50	292	17.38	441	11.75	298	7.00	1178
1.00	25	12	HA	12.5	318	16.50	419	10.88	276	17.38	441	11.75	298	7.00	1178
2.00	50		WM			20.25	521	14.62	371	20.50	521	14.38	365	10.00	254

\*Clearance required for "Direct Actuator" cover removal.

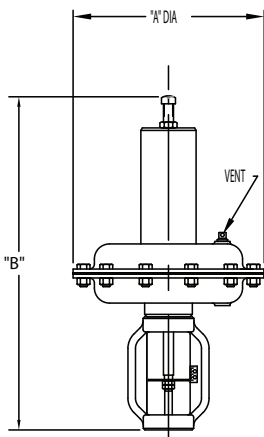

**Fig. 12**  
Reverse Actuator  
Series 2200

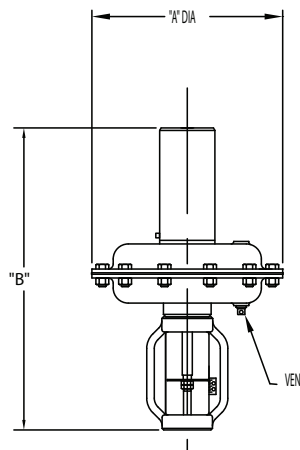

**Fig. 13**  
Direct Actuator  
Series 2200

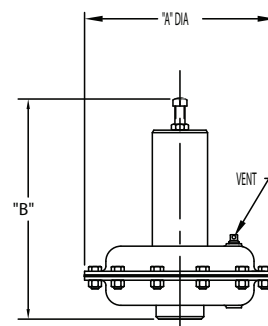

**Fig. 14**  
Reverse Actuator  
Series 2220

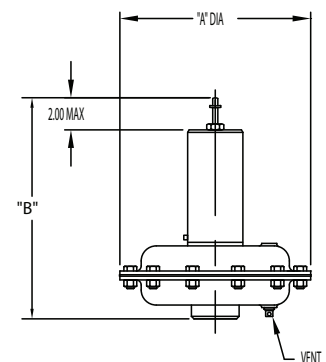

**Fig. 15**  
Direct Actuator  
Series 2220

## How to Order

1. Select the valve by series number: 2200 (with yoke) or 2220 (close coupled)
2. Select body size
3. Select model number

### BODY CONNECTIONS

Size	Code
Screwed Female NPT	S
Flanged Raised Face	RF
Flanged Ring Type Joint	RJ
Flanged Flat Face	FF
Beveled Butt weld	B*
Socket weld	W*

\*Schedule Required

### BODY SIZE

Size	Code
1.00"	1
2.00"	2

### VALVE SERIES

Series	Code
Open Yoke	2200
Close Coupled	2220

### SPECIAL COMPONENTS

Body/Bonnet	Code
WCC/A696	-
CF8M/316	S
WCC/A696 <sup>(1)</sup>	N
CF8M/316 <sup>(1)</sup>	R
LCC/A350 LF2 <sup>(1)</sup>	P

### BODY RATING

ANSI Class	Code
150	02
300	07
600	14
900	21
1500	36
2500	60

### ACTUATOR ACTION

Mode	Code
Direct (Fail Open)	B
Reverse (Fail Close)	T
Manual (Handwheel)	F

### BODY STYLE

Type	Code
Angle	A
Globe	G
"T"	T

(1) Suitable for NACE

### ACTUATOR SPRINGS

Code	Actuator Number
NN, AA, HA*	9
HA, WM*	12

\*See Table 11

### ACTUATOR SIZE

Code	Number
"00"	None
9	9
12	12
EC	Electric

### PACKING

Code	Material	Load Type	Temp. Rating
-	TFE V-Ring	Non - Adj.	-120°+400°F -84°+204°C
C	Fabric V-Ring	Non - Adj.	-20°+250°F -28°+121°C
N <sup>(1)</sup>	TFE V-Ring	Non - Adj.	-120°+400°F -84°+204°C
Fugitive Emission Packing			
L	Viton/TFE	Non - Adj.	15°+400°F -26°+204°C

### SEAL MATERIAL

Code	Wetted	Diaphragm
A	Buna	Buna
K	Viton <sup>(1)</sup>	Buna
L	Low Temp. Buna	Buna
V	Viton	Buna
7	HSN <sup>(1)</sup>	Neoprene
8	HSN <sup>(1)</sup>	Viton

**I-2200 S-36TGA-9AA**

## Accessories:

Positioners (Electro-Pneumatic, Pneumatic and Digital), Airlock, Limit Switches, Solenoid Valve, Booster Relay, Filter Regulators, I/P Transducers, Pressure Controllers, Temperature Controllers, etc.

## ***Why you can depend on genuine Norriseal products***

- In-house engineering and technical support
- In-depth applications experience
- Award-winning innovation and ongoing product development
- ISO 9001-certified manufacturing
- Over five decades of industry service
- Compliance with all industry standards and specifications
- Responsive service and prompt delivery
- Field support available worldwide

*Please contact your Norriseal representative for more details and assistance in specifying the optimal solution for your application.*



***Engineered Performance***

**11122 West Little York • Houston, Texas 77041**

**Tel: 713-466-3552 • Fax: 713-896-7386**

**[www.norriseal.com](http://www.norriseal.com)**

Due to the continuous improvement program at Norriseal, specifications and/or prices are subject to change without notice or obligation. Envirosave is a mark of Norriseal, A Dover Company. All other trademarks contained herein are the property of their respective owners.

© 2011 Norriseal, A Dover Company

2200-1211T