

# Examine The Norris 285 Series Butterfly Valves



**M285**



**R285**

Meets ANSI B16.5 Code for Class 150 Flange Pressure/Temperature Rating • Sizes 2 1/4" through 36"

Solutions through engineered products.

**NORRISEAL**  
A **DOVER** RESOURCES COMPANY

# R285 SERIES

It's the lowest priced long-life butterfly valve with a pressure/temperature rating which meets ANSI B16.5 Code for Class 150 flanges.

## **Lowest priced because it is completely lined**

The flow stream never touches the body. There is no need for a costly high-alloy body even in corrosive service. The removable elastomer seat is easily replaced on-site in minutes.

## **It gives you positive shutoff with Norris angle-disc design proven by 25 years of day-in, day-out service**

Disc does not seat in shaft holes, assuring bubble-tight shutoff with no scrubbing or compression set in the shaft hole area. Resilient seats are made from high-density elastomers which are highly resistant to deterioration by flow media.

## **Norris R285 Series valves are intended for use between ANSI B16.5 Class 150 WELDNECK flanges**

The schedule 40 inside diameter of the flange is needed to provide proper seat support at the higher working pressure...200 psi and greater.

## **Flange gaskets are not required**

Separate replaceable body O-ring flange seals eliminate need for flange gaskets. Flange seals can be changed, if necessary, without dismantling the valve and replacing the seat. Often a damaged flanged seal needn't be replaced at all, but simply turned over and inserted back in the body face groove.

## **There is no need for scheduled lubrication**

Four O-ring shaft seals lock in factory lubricant. Along with the primary seal molded into the elastomer seat shaft hole, these seals provide protection against leakage into body shaft bearing areas.

Four self-lubricated steel-backed shaft bushings reduce operating torque and prevent galling of the shaft. Bushings are designed to operate above temperature limits of elastomer seats and seals with a two to one safety factor at full differential pressure.

## **Greater flow efficiency and lower operating torque**

The Norris R 285 Series butterfly valve gives you much greater flow efficiency and lower operating torque than conventional offset disc valves which meet pressure/temperature requirements of ANSI B16.5 Code for Class 150 flanges.

## **It gives you bi-directional flow with no loss in flow efficiency**

The symmetrical disc design of Norris angle-disc valves gives you the same highly efficient flow in both directions. Since the flow area is equal on both sides of the thru-shaft, no unbalanced flow occurs as is experienced in conventional offset disc designs.

## **It gives you a 285 psi rating with reserve strength to handle sudden differential pressure surges**

This means added protection against water-hammer and other unexpected overloads. Every valve is strength tested before shipment...shell tested to 150% (430 psig) of rated pressure with the disc open. Every valve is tested for positive shutoff...differentially tested to 110% (315 psig) of rated working pressure with the disc closed. Every valve is tested for leakage into the shaft bearing area...set screw is removed during differential and shell testing to assure there is no leakage into this area.

- **100% bubble-tight positive shutoff**
- **Full rated bi-directional shutoff**
- **Field replaceable resilient liner**
- **Non-wetted body design**
- **Wide selection of materials available**

# R285 SERIES

## It gives you extra strength with a thru-shaft

High-strength full-length shaft is cross pinned to the disc with large diameter solid, round pin which is field removable. This connection is stronger than the torsional strength of the shaft itself. The disc pin does not penetrate sealing surface of the disc. Shafts are manufactured from premium performance material — 17-4PH stainless, K-Monel.

## Each disc is individually centered to prevent leakage through the valve bore

Precision thrust bearings keep disc in precisely centered alignment with seat, assuring reliable, bubble-tight seating throughout the life of the valve.

## Valve is "self-cleaning"

Smooth disc contours resist dirt build up and turbulence.

## Norris gives you a choice of actuators

All actuators fitting Norris 200 psi models fit the R285 Series... lever handles, gear operators, diaphragm actuators, air cylinder assemblies and electric operators.

Compare Norris R Series with the valves you're using now... then call for our application engineering department. We'll fill you in on all the Norris money saving angles and help you select a Norris R Series valve for your next application.

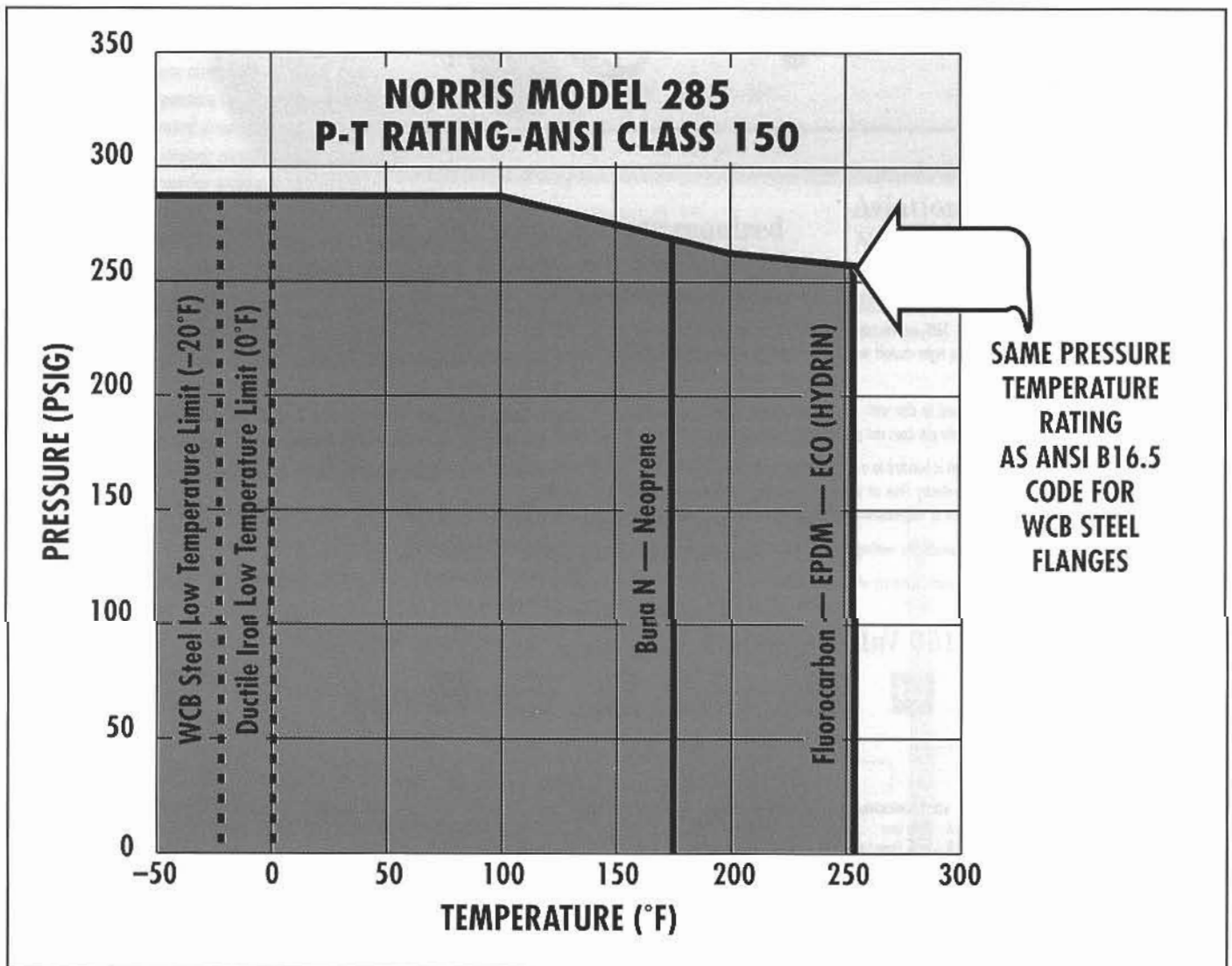

# R285 SERIES

2½" thru 36"  
Norris Butterfly Valves

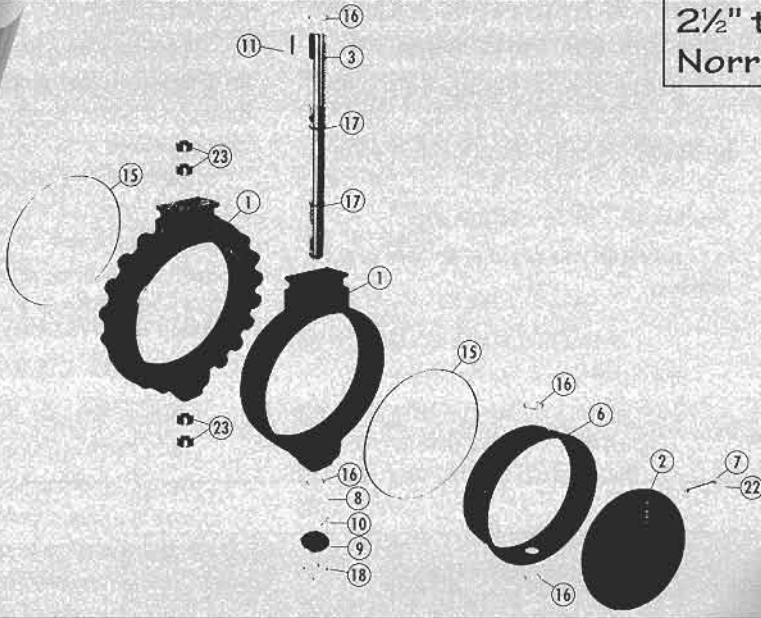

## PARTS DESCRIPTION

- 1 **BODY** — Valve body is isolated from flow stream by resilient seat and O-ring seals. Bodies have shaft bushings for handling shaft loads and to provide minimum operating torque.
- 2 **DISC** — Angle disc construction gives 360° uninterrupted contact of disc with seat. Disc does not seat in shaft holes, assuring bubble-tight shutoff time after time with no scrubbing of the elastomer in the shaft hole areas.
- 3 **SHAFT** — Through shaft, cross pinned to disc with straight dowel pin, assures maximum drive strength and field repairability. Disc pin does not penetrate the sealing plane of the disc.
- 6 **SEAT** — Field replaceable resilient seat is bonded to a rigid backing ring to prevent seat from distorting or collapsing due to high velocity flow or in vacuum service. Rigid backing also prevents seat collapse during installation of valve between flanges.
- 7 **DISC PIN** — Round pin does not penetrate the sealing plane of the disc.
- 8 **SHIM SET** — Assures proper support and centering of disc in seating area.

- 9-10 **THRUST PLATE & WASHER** — Retains shaft from bottom.
- 11 **KEY** — Provides precision fit with operator. (14" & larger)
- 15 **BODY O-RINGS** — Body O-ring flange seals eliminate need for flange gaskets. Flange seals can be replaced without dismantling the valve and replacing the seat. Many times a damaged O-ring flange seal can be repaired simply by turning it over and returning it to the body face groove.
- 16 **O-RING SEAT AND SHAFT SEALS** — Seat and shaft seals prevent stem leakage to atmosphere and permanently lubricated areas; protect from outside contamination.
- 17 **O-RING DISC/SHAFT SEALS** — Seals prevent leakage across disc plane.
- 18 **THRUST PLATE CAPSCREWS** — To retain bottom thrust plate. (Not Shown)
- 22 **DISC PIN CAPSCREWS** — To retain disc pin. (Not Shown)
- 23 **SHAFT BUSHINGS** — Self-lubricated steel-backed shaft bushings reduce operating torque and prevent galling of the shaft.

## ANSI 150 Valve — Model Number Designations (Typical Model Number)

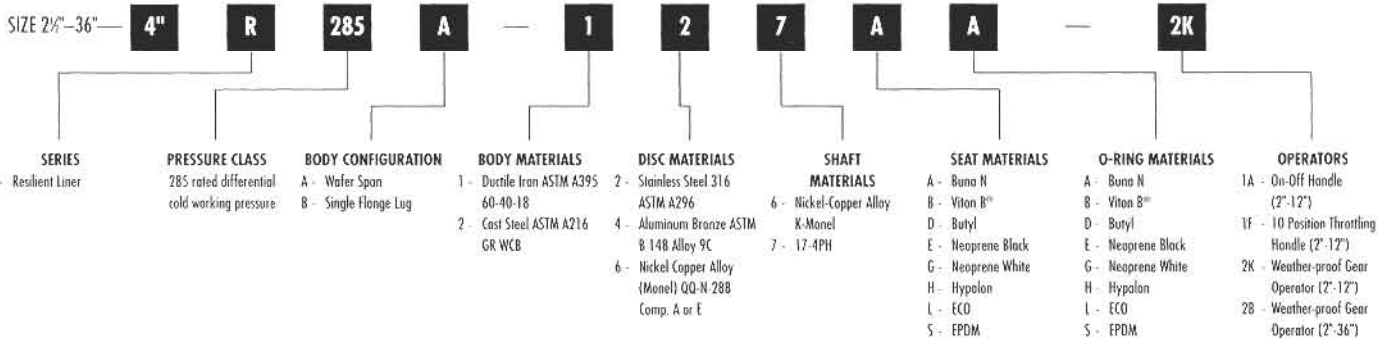

Code sequence above identifies 4 in./resilient liner/285 wp/wafer span/ductile iron body/316 SS disc/17-4 PH shaft/Buna N liner and O-ring seals/manual gear operator.

® Registered trade mark of DuPont de Nemours

# M285 SERIES

## 285-psi-rating, with reserve strength to handle sudden differential pressure surges

This means added protection against water-hammer and other unexpected overloads.

## Every valve is strength-tested

Shell tested to 150% (430 psig) of rated pressure with the disc open... hydrostatically tested for bi-directional positive shutoff without leakage at 110% (315 psig) of rated working pressure... also tested for absence of leakage into shaft bearing areas. Only valves that meet all of these POSITIVE SHUTOFF standards are approved for shipment.

## Longer life

Long-life, because almost endless trim material combinations are possible for the disc, liner and O-ring seals — to control even the most destructive flow streams. Any elastomer available in standard O-ring form can be used for sealing M285 valves.

## Long-life because the flow stream never touches the body

Shaft O-ring seals, and field replaceable metal liner keep the body dry.

## Bi-directional flow with no loss in flow efficiency

The flow area is equal on both sides of the thru-shaft with Norris' symmetrical angle-disc design. There is less turbulence and reduced fluid dynamic torque than in "high-performance" butterfly valves with offset discs.

The redesigned, bi-directional disc O-ring groove (patent applied for) assures positive shutoff in both flow directions.

## Easy on-site maintenance

No special tools required, takes only minutes. Replacing a part will not affect positive shutoff characteristics of the valve.

## No need for scheduled lubrication

Shaft is factory lubricated, protected against leakage by four O-ring seals. Four self-lubricated steelbacked shaft bushings reduce operating torque and prevent galling of the shaft.

## No flange gaskets required

Separate body O-ring flange seals are replaceable in minutes without dismantling the valve.

## A choice of actuators

Lever handles, gear operators, diaphragm actuators, cam-operated cylinder assemblies, and electric operators.

**Norris M285 valves are intended for use between ANSI B16.5 Class 150 flanges.**

## Application Engineering assistance

Call 1-713-466-3552, we'll help you select the correct Norris M285 valve for each application.

## Norris M285: For Chemical Industries

Norris valves with stainless steel, Inconel, Hastelloy, Titanium or Zirconium discs and liners and Viton®, Buna N, EPDM, or Neoprene seals solve difficult valving problems in the chemical processing industry — without repairs — over long service periods.

## Norris M285: Now in Aviation Fueling Systems Nationwide

M285 valves are ideal for handling volatile materials such as gasolines, jet fuels, and solvents which tend to dry elastomers.

- Metal-lined positive shutoff
- Non-wetted body design
- Full bi-directional shutoff
- Teflon® sealing available
- Wide selection of materials available

# M285 SERIES

## Norris M285: for marine service

For many years Norris valves have met Navy specifications for services such as bilge, ballast, fire mains, etc. They also satisfy MIL-V-16468 for positive shutoff of hydrocarbon fuels on shipboard.

During the 1970s, in fire tests by the U.S. Coast Guard, Norris valves satisfactorily handled flammable liquids in a fire situation. The Coast Guard has qualified Norris metal-lined valves for critical positive shutoff services on shipboard according to Paragraph 56.50-60.

## Norris M285: for the petroleum industry

M-Series valves meet the many requirements on loading racks and manifolds, in tank farms and distribution systems.

They are approved for control of poisonous hydrogen sulfide gas and other services near the wellhead.

## M-Series valves meet industry standards around the world

Norris M-Series split-shaft valves were the first butterfly valves to be approved under U.S. Navy Specifications MIL-V-16468 which covers positive shutoff valves for hydrocarbon service on shipboard.

Norris M-Series valves also meet the following standards:

### Commercial Marine Standards

U.S. Coast Guard Marine Engineering Regulations, Subchapter F (CG-115) and 46 CFR 56.50-60 (d); American Bureau of Shipping, Rules for the Classification and Construction of Steel Vessels; Det Norske Veritas (DNV), Oslo, Norway; Lloyd's Register of Shipping, London, England;

### Industrial Butterfly Valve Standards

MSS Standard Practice SP-67 Butterfly Valves; American Petroleum Institute — Refinery

Division (API) Standard 609 Valve Body Dimensions and Pressure-Temperature Rating for Butterfly Valves;

### Piping Standards Which Influence Valve Selection

American National Standards Institute (ANSI) — Standards for Flanges and Fittings — B16.5 Code for Pressure/Temperature Rating of Class 150 Flanges; Deutsches Institut for Normung e.V. (DIN) — Standards for Flanges; Japanese Industrial Standards (JIS) — Flange Standards; British Standards Institute (BSI) — Flange Standards

*Special drilling or notching of Norris Valves is required for use with DIN, JIS, and BSI flanges. Consult factory for details.*

## NORRIS MODEL 285 P-T RATING-ANSI CLASS 150 M-SERIES

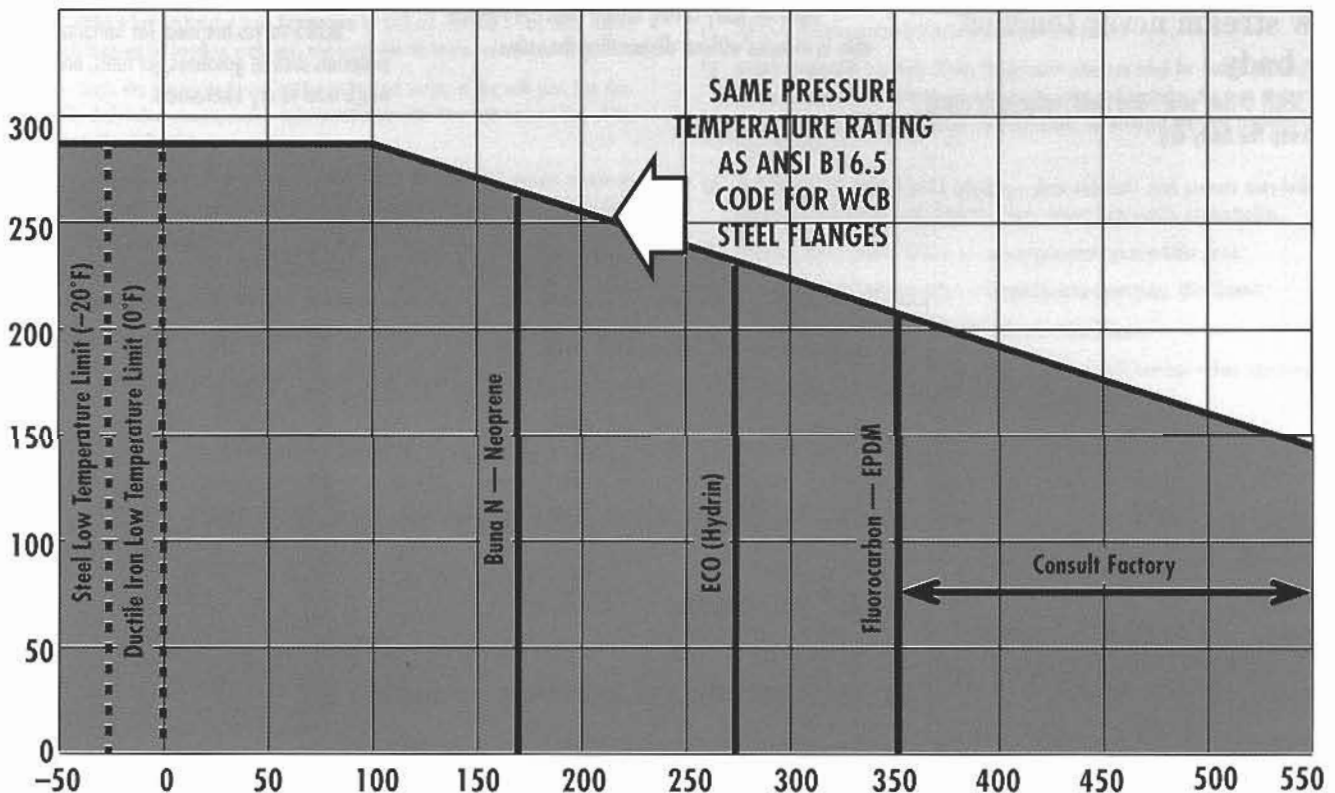

# M285 SERIES

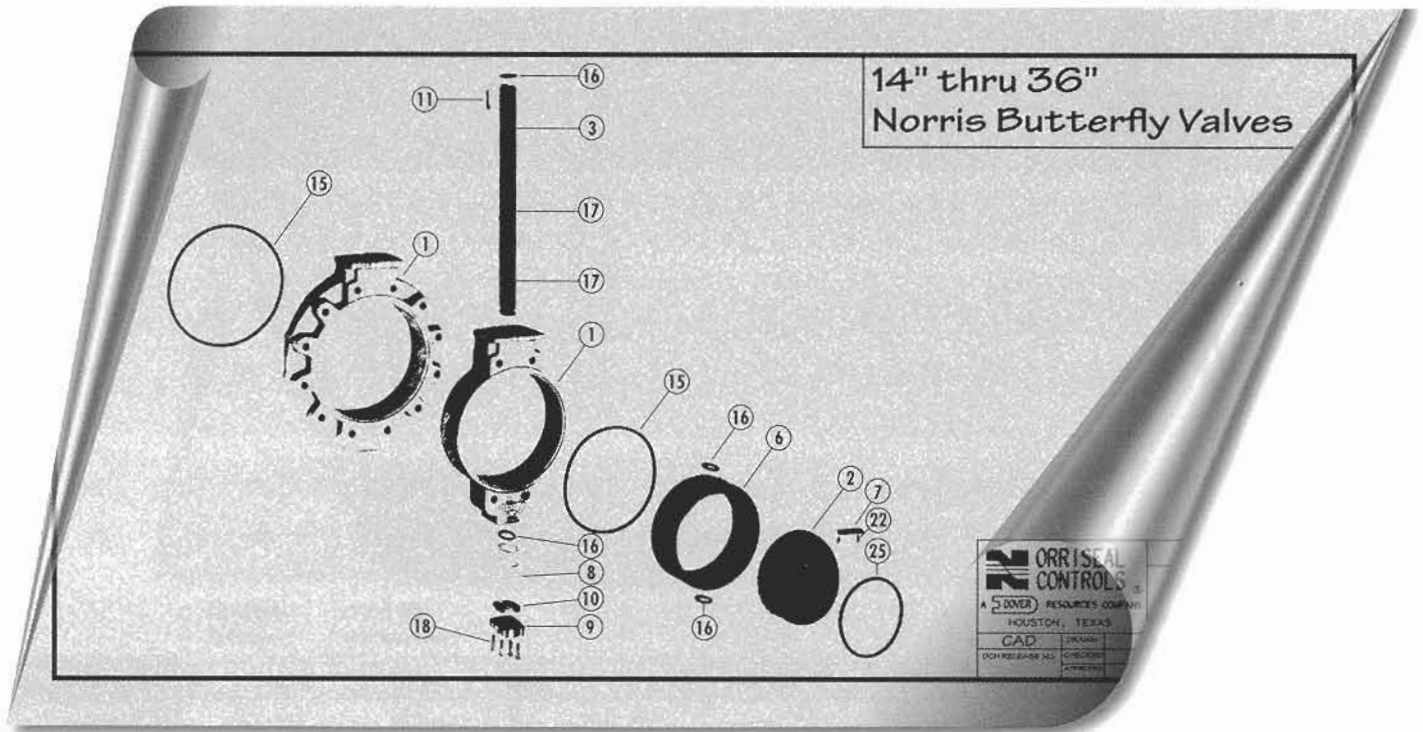

## PARTS DESCRIPTION

- 1 **BODY** — Available in span and lug type.
- 2 **DISC** — Angle-disc construction gives 360 degree uninterrupted contact of disc O-ring seal with metal liner for dependable positive shutoff.
- 3/7 **SHAFT/DISC PIN** — Through shaft is cross pinned to disc with large diameter solid straight pin, assuring disc/shaft/pin interchangeability. Disc pin does not penetrate sealing plane of the disc... is positively retained with two cap screws.
- 6 **LINER** — Field-replaceable metal liner isolates valve body from flow stream, eliminates need for premium body material even when handling corrosive media.
- 8/9/10 **SHIM SET/THRUST PLATE & WASHER** — Assures proper disc/seat support and perfectly centers disc in seating area for positive shutoff throughout the life of the valve.
- 11 **KEY** — Provides precision fit with operator (14" and larger.) Double key slot is standard so valve action is easily reversed. (Not shown.)
- 15 **BODY O-RINGS** — Body-O-ring flange seals eliminate need for flange gaskets... can be replaced without dismantling the valve.
- 16 **O-RING SEAT AND SHAFT SEALS** — Double shaft/bushing seals prevent stem leakage... protect from internal or external contamination. Internal seals are 100% tested to assure there is no leakage behind the liner.
- 17 **O-RING DISC/SHAFT SEALS** — Double seals prevent leakage thru disc/shaft hole.
- 18 **THRUST PLATE CAPSCREWS** — Retain bottom thrust plate.
- 22 **DISC PIN CAPSCREWS** — Retain disc pin. Stainless steel or K-Monel.
- 23 **SHAFT BUSHINGS** — Self lubricated steel-backed bushings reduce operating torque and prevent galling of the shaft.
- 25 **DISC O-RING SEAL** — O-ring contained in specially designed groove in disc edge (patent applied for) assures bi-directional positive shutoff.

## ANSI 150 Valve — Model Number Designations (Typical Model Number)

SIZE 2 1/4"–36"	4"	M	285	A	1	4	7	3	A	2B
<b>SERIES</b>		M - Metal Liner								
<b>PRESSURE CLASS</b>		285 rated differential cold working pressure								
<b>BODY CONFIGURATION</b>		A - Wafer Span B - Single Flange Full Lug F - Long Neck Wafer Span G - Long Neck Full Lug								
<b>BODY MATERIALS</b>		1 - Ductile Iron ASTM A395 60-40-18 2 - Cast Steel ASTM A216 GR WCB 5 - Stainless Steel 316 ASTM A743 GR CF-8M								
<b>DISC MATERIALS</b>		2 - Stainless Steel 316 ASTM A743 GR CF-8M 3 - Stainless Steel Alloy #20 4 - Aluminum Bronze ASTM B148 Alloy 9C 6 - Nickel Copper Alloy (Monel) QQ-N-288 Comp. A or E 9 - Titanium OMC-103 with 0.15% Palladium B - Hastelloy B ASTM A494 C - Hastelloy C ASTM A494 G - Inconel 600 or 610 K - Ilium PD N - Zirconium								
<b>SHAFT MATERIALS</b>		6 - Nickel Copper Alloy K-Monel 7 - 17-4PH								
<b>SEAT MATERIALS</b>		2 - Stainless Steel Type 316 ASTM A743 GR CF-8M 3 - Aluminum Bronze ASTM B148 Alloy 9B 5 - Nickel Copper Alloy (Monel) QQ-N-288 Comp. A or E 6 - Inconel 600 or 610 7 - Stainless Steel Alloy #20 8 - Ilium PD 9 - Titanium OMC-103 with 0.15% Palladium B - Hastelloy B ASTM A494 C - Hastelloy C ASTM A494 D - Zirconium								
<b>O-RING MATERIALS</b>		A - Buna N B - Viton 8" D - Butyl E - Neoprene Black G - Neoprene White H - Hypalon L - FCO S - EPDM Y - Kalrez (Disk O-Ring Only)								
<b>OPERATORS</b>		1A - On-Off Handle (2 1/2" x 12") 1F - 10 Position Throttling Handle (2 1/2" x 12") 2K - Weather-proof Gear Operator (2 1/2" x 12") 2B - Weather-proof Gear Operator (2 1/2" x 36") 2G - Weather-proof Diaphragm Operator 2C - Weather-proof Cam Operated Cylinder Assembly								

® Registered trade mark of DuPont de Nemours

# R285B 2½"-12" VALVES CERTIFIED DIMENSIONS

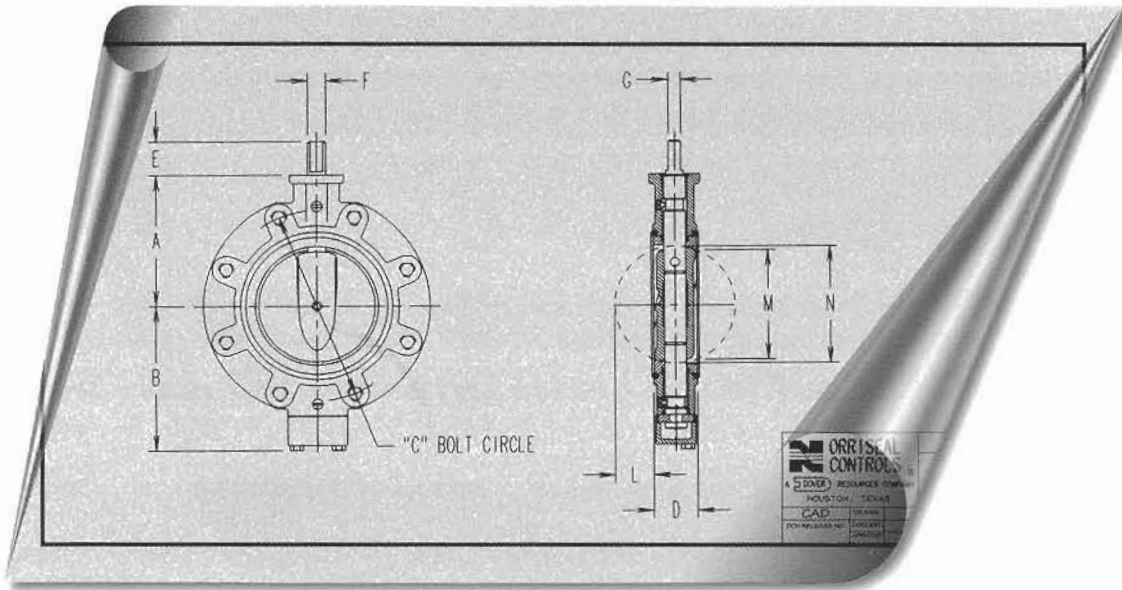

## Valve Dimensions

Dimension Reference	Valve Size (Inches/mm)		2.5/65	3/80	3.5/90	4/100	5/125	6/150	8/200	10/250	12/300
A			4.16	4.41	4.63	4.88	5.28	6.50	7.47	9.38	10.41
B			4.48	4.86		5.31	5.72	7.27	8.22	9.92	10.96
C			5.50	6.00	7.00	7.50	8.50	9.50	11.75	14.25	17.00
D			1.75	1.75	1.94	2.00	2.13	2.13	2.50	2.50	3.00
E			1.31	1.31	1.31	1.31	1.31	1.69	1.69	2.00	2.00
F			.69	.69	.69	.69	.69	.88	.88	1.06	1.06
G			.50	.50	.50	.50	.50	.63	.63	.75	.75
H			.88	.88	.88	.88	.88	1.06	1.06	1.38	1.38
J			.25	.25	.25	.25	.25	.38	.38	.38	.38
K			1.81	1.81	1.81	1.81	1.81	2.34	2.34	2.63	2.63

## Disc Clearance

L	.50	.75	.94	1.13	1.56	1.94	2.69	3.75	4.50
M	2.06	2.69	3.16	3.59	4.72	5.55	7.44	9.58	11.52
N	2.72	3.20	3.72	4.19	5.17	5.91	7.81	9.89	11.89

Approx. Wt.  
Cast Iron Body

	8	10	12	16	20	26	40	62	87
--	---	----	----	----	----	----	----	----	----

## Bolt Data

**FOR USE WITH ANSI CLASS 150 WELDNECK FLANGES.** For optimum valve performance, it is recommended that butterfly valves be installed between weldneck flanges or flanges with equivalent inside dimensions.

Capscrew Size*	.63Wcx1.50	.63Wcx1.75	.63Wcx1.75	.63Wcx1.75	.75Wcx1.75	.75Wcx2.00	.75Wcx2.25	.88Wcx2.25	.88Wcx2.50
Number Required	8	8	16	16	16	16	16	24	24

\*Through-tapped from face to face for studs or capscrews unless specified otherwise.

## Operator Dimensions

P	9.94	9.94		9.94	9.94	15.00	15.00	16.00	16.00
Q	3.34	3.34		3.34	3.34	3.66	3.66	3.66	3.66
R	6.88	6.88		6.88	6.88	7.50	7.50	8.00	8.00
S	6.00	6.00		6.00	6.00	8.00	8.00	8.00	8.00
T	2.36	2.36		2.36	2.36	2.36	2.36	3.00	3.00
U	3.50	3.50		3.50	3.50	3.50	3.50	4.38	4.38
V	5.93	5.93		5.93	5.93	5.93	5.93	7.50	7.50
W	5.25	5.25		5.25	5.25	5.25	5.25	6.75	6.75
X	2.92	2.92		2.92	2.92	2.92	2.92	3.27	3.27
Y	2.63	2.63		2.63	2.63	2.63	2.63	2.63	2.63
Z	1.69	1.69		1.69	1.69	1.69	1.69	1.88	1.88

Approx. Wt.  
2R & 2RM Operator

	7	7		7	7	8	8	13	13
--	---	---	--	---	---	---	---	----	----

NOT AVAILABLE

# R285B 14"-36" VALVES CERTIFIED DIMENSIONS

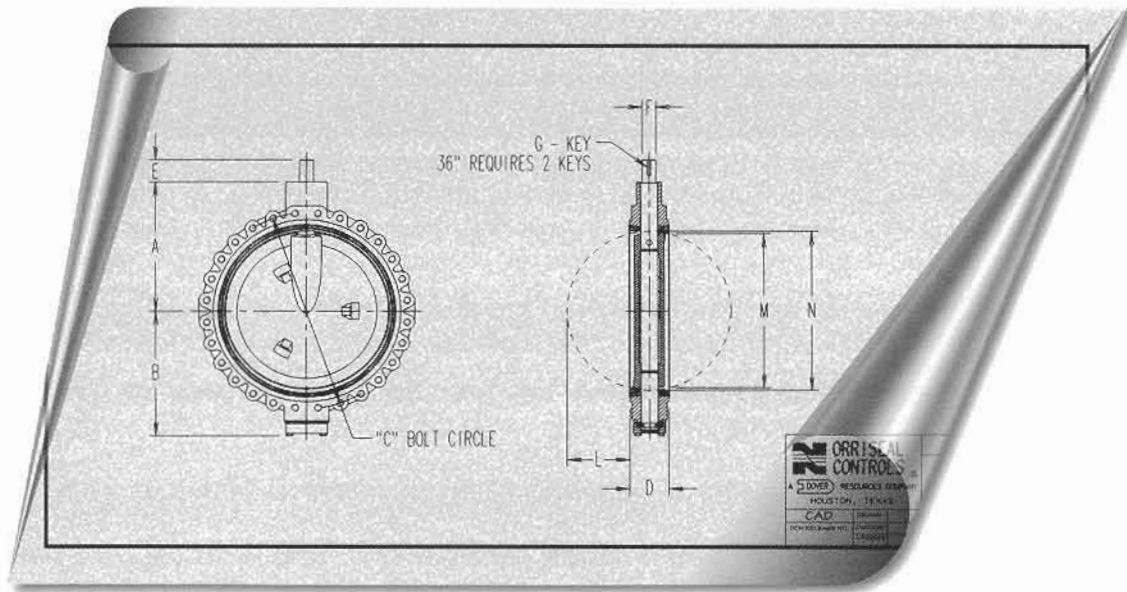

## Valve Dimensions

	14/350	16/400	18/450	20/500	22/550	24/600	26/650	28/700	30/750	32/800	36/900
A	12.63	14.00	14.75	16.00	17.38	17.50	20.13	22.75	23.75	24.50	26.13
B	14.25	15.63	16.63	17.88	18.00	19.00	20.61	21.83	22.70	24.23	29.38
C	18.75	21.25	22.75	25.00	27.25	29.50	31.75	34.00	36.00	38.50	42.75
D	3.75	4.13	4.63	5.13	5.00	5.00	6.00	6.50	7.00	7.00	8.50
E	3.94	3.94	3.94	3.94	3.94	3.94	3.94	3.94	3.94	3.94	4.75
F	1.75	1.75	1.75	2.50	2.50	2.50	2.50	2.50	2.50	2.50	3.00
G	.38x2.5	.38x2.5	.38x2.5	.63x2.94	.63x2.94	.63x2.94	.63x2.94	.63x2.94	.63x2.94	.63x2.94	.75x3.0
H	1.75	2.00	2.25	2.50	2.50	2.50	3.00	3.00	3.00	3.50	3.50
J	.63	.63	.63	.63	.63	.63	.75	.75	.75	.75	.75
K	1.50	1.50	1.50	1.50	1.50	1.50	1.50	1.50	1.50	1.50	1.50

## Disc Clearance

L	4.79	5.61	6.36	7.14	8.19	9.19	9.60	10.36	11.10	11.96	12.88
M	12.80	14.78	16.72	18.72	20.75	22.83	24.50	26.38	28.50	30.13	34.25
N	13.34	15.34	17.34	19.41	21.33	23.38	25.51	27.21	29.21	30.96	35.25

Approx. Wt.-  
Cast Iron Body

	200	290	370	460	485	531	810	980	1080	1130	1795
--	-----	-----	-----	-----	-----	-----	-----	-----	------	------	------

## Bolt Data

**FOR USE WITH ANSI CLASS 150 WELDNECK FLANGES.** For optimum valve performance, it is recommended that butterfly valves be installed between weldneck flanges or flanges with equivalent inside dimensions.

Capscrew Size	1.00NCx3.00	1.00NCx3.00	1.13NCx3.50	1.13NCx3.50	1.25NCx4.00	1.25NCx4.00	1.25NCx4.00	1.25NCx4.00	1.25NCx4.00	1.50NCx4.50	1.50NCx4.50
Number Required (Both Required)	24	32	32	32	32	40	40	48	48	48	64
Capscrew Size			1.13NCx3.00	1.25NCx3.50			1.25NCx3.50	1.25NCx3.25	1.25NCx3.50	1.50NCx3.75	1.50NCx4.00
Number Required	N.A.	N.A.	N.A.	8	8	N.A.	8	8	8	8	8

## Operator Dimensions

R	9.75	9.75	9.75	17.25	17.25	17.25	17.84	17.84	17.84	17.84	17.84
S	12.75	12.75	12.75	24.00	24.00	24.00	24.00	24.00	24.00	24.00	24.00
T	4.83	4.83	4.83	5.38	5.38	5.38	2.69	2.69	2.69	2.69	7.13
U	6.63	6.63	6.63	7.63	7.63	7.63	9.44	9.44	9.44	9.44	10.81
V	10.13	10.13	10.13	11.13	11.13	11.13	14.94	14.94	14.94	14.94	16.31
W	9.00	9.00	9.00	10.81	10.81	10.81	12.00	12.00	12.00	12.00	14.00
X	5.00	5.00	5.00	5.14	5.14	5.14	7.38	7.38	7.38	7.38	7.75
Y	4.50	4.50	4.50	N.A.	N.A.	N.A.	N.A.	N.A.	N.A.	N.A.	N.A.
Z	2.88	2.88	2.88	2.88	2.88	2.88	4.00	4.00	4.00	4.00	4.00

Approx. Wt.

2T & 2TM Operator	70	70	70	90	90	90	90	210	210	210	260
-------------------	----	----	----	----	----	----	----	-----	-----	-----	-----

# NORRISEAL LOCATIONS

## Company headquarters, manufacturing plant and International Sales

P.O. Box 40525 • Houston, TX 77240-0525  
11122 West Little York • Houston, TX 77041  
Phone: (713) 466-3552 • Fax: (713) 896-7386

## Branches

### Western Louisiana

102B Burgess Drive • Broussard, LA 70518  
Phone: (337) 837-3223 • Fax: (337) 837-3448

### Eastern Louisiana

2304B Engineers Road • Belle Chasse, LA 70037  
Phone: (504) 394-3646 • Fax: (504) 394-8765



REPRESENTED BY:

Solutions through engineered products.

**NORRISEAL**<sup>®</sup>  
A **DOVER** RESOURCES COMPANY

<http://www.norriseal.com>

2.5M-6/01  
MJ15915